

Tutorials and Reference Guide



LISA Finite Element Analysis

Software Version 8.0.0

2013

Contents

Chapter 1

Overview of LISA 6

- 1.1 Mesh, 6
- 1.2 Analysis, 7
- 1.3 Geometry, 7
- 1.4 Components & Materials, 7
- 1.5 Named Selections, 7
- 1.6 Loads & Constraints, 7
- 1.7 Solution, 7

Chapter 2

Viewing and Selecting 8

- 2.1 Zoom, Pan, Rotate, 8
- 2.2 Display modes, 9
- 2.3 Selection, 10

Chapter 3

Units 13

Chapter 4

Mesh Creation 16

- 4.1 Manual meshing, 16
- 4.2 Symmetry, 26
- 4.3 Mesh refinement, 28
- 4.4 Mesh information, 29
- 4.5 Modeling errors, 30

Chapter 5

CAD Models 34

- 5.1 Introduction, 34
- 5.2 Automeshed CAD models default to millimeters, 36
- 5.3 Local refinement tutorial, 37
- 5.4 CAD assemblies, 38

Chapter 6

Analysis Types

39

- 6.1 Static, 39
- 6.2 Modal Vibration, 40
- 6.3 Modal Response, 42
- 6.4 Dynamic Response, 43
- 6.5 Buckling, 45
- 6.6 Thermal, 47
- 6.7 Fluid Potential Flow, 50
- 6.8 Fluid Navier-Stokes Equations, 51
- 6.9 Fluid Non-Newtonian Conduit Cross-Section, 52
- 6.10 DC Current Flow, 53
- 6.11 Electrostatic, 53
- 6.12 Magnetostatic 2D, 54
- 6.13 Acoustic Cavity Modes, 54

Chapter 7

Elements

56

- 7.1 Plane Continuum Elements, 56
- 7.2 Axisymmetric Continuum Elements, 57
- 7.3 Solid Continuum Elements, 57
- 7.4 Shell, 58
- 7.5 Beam, 59
- 7.6 Truss, 61
- 7.7 Axial Spring, 62
- 7.8 Fin, 63
- 7.9 Resistor, 63

Chapter 8

Materials

64

- 8.1 Materials database, 64
- 8.2 Defining a new material, 64
- 8.3 Mixed materials, 64
- 8.4 Mixed elements, 65
- 8.5 Orthotropic & anisotropic materials, 66
- 8.6 Temperature dependent properties, 66

Chapter 9

Loads and Constraints

67

- 9.1 Fixed Support, 67
- 9.2 Displacement, 67
- 9.3 Flexible Joint, 67

- 9.4 Force, 68
- 9.5 Pressure, 68
- 9.6 Line Pressure, 68
- 9.7 Moment, 68
- 9.8 Gravity, 69
- 9.9 Centrifugal Force, 69
- 9.10 Tension Per Length, 69
- 9.11 Temperature, 69
- 9.12 Thermal Stress, 70
- 9.13 Pressure Gradient Z, 72
- 9.14 Heat Flow Rate, 72
- 9.15 Internal Heat Generation, 72
- 9.16 Flow Rate, 72
- 9.17 Voltage, 72
- 9.18 Charge, 72
- 9.19 Current, 73
- 9.20 Magnetic Vector Potential, 73
- 9.21 Convection, 73
- 9.22 Radiation, 73
- 9.23 Robin Boundary Condition, 73
- 9.24 Cyclic Symmetry, 74
- 9.25 Stress Stiffening, 76
- 9.26 Loads and Constraints on Nodes, 76
- 9.27 Coupled DOF, 79
- 9.28 Load Cases, 80
- 9.29 Time Dependent Loads, 80

Chapter 10

Results 81

- 10.1 Display, 81
- 10.2 File Output, 84

Chapter 11

Samples and Verification 85

- 11.1 BeamBendingAndTwisting.liml, 85
- 11.2 CylinderLifting.liml, 86
- 11.3 PressureVesselAxisymmetric.liml, 88
- 11.4 TwistedBeam.liml, 89
- 11.5 BucklingBeam.liml, 90
- 11.6 BucklingPlate.liml, 90
- 11.7 FinConvection.liml, 92
- 11.8 ConductionConvectionRadiation.liml, 93
- 11.9 OscillatingHeatFlow.liml, 94
- 11.10 FluidPipeXSection.liml, 96
- 11.11 FluidPseudoplastic.liml, 97

- 11.12 FluidBingham.liml, 98
- 11.13 FluidPotentialCylinder.liml, 99
- 11.14 FluidStep.liml, 100
- 11.15 FluidCouette.liml, 101
- 11.16 FluidViscousCylinder.liml, 102
- 11.17 VibratingFreePlate.liml, 104
- 11.18 VibratingCantileverBeam.liml, 105
- 11.19 VibratingCantileverSolid.liml, 106
- 11.20 VibratingTrussTower.liml, 107
- 11.21 VibratingMembrane.liml, 108
- 11.22 VibratingMembraneCyclicSymmetry.liml, 109
- 11.23 VibratingString.liml, 110
- 11.24 PandSWaves.liml, 111
- 11.25 WheatstoneBridge.liml, 113
- 11.26 Capacitor.liml, 114
- 11.27 MagnetWire.liml, 115

Chapter 12

Automation and Batch Processing 116

- 12.1 Command Line Parameters, 116
- 12.2 COM Interface, 116

Chapter 13

FEA Math 118

- 13.1 Variational Principle, 118
- 13.2 Explaining the Functional $V(u(x))$, 118
- 13.3 Shape Functions, 119
- 13.4 Minimizing the Functional $V(u(x))$, 119

Chapter 14

License Agreements 120

- 14.1 LISA, 120
- 14.2 ARPACK, 120
- 14.3 Netgen nglib, Pthreads-win32 and ZedGraph, 120
- 14.4 GNU Lesser General Public License, 120
- 14.5 OCC CAD Kernel, 123

Chapter 15

References 125

Overview of LISA

This chapter introduces you to the LISA work-flow for accomplishing your finite element analysis.

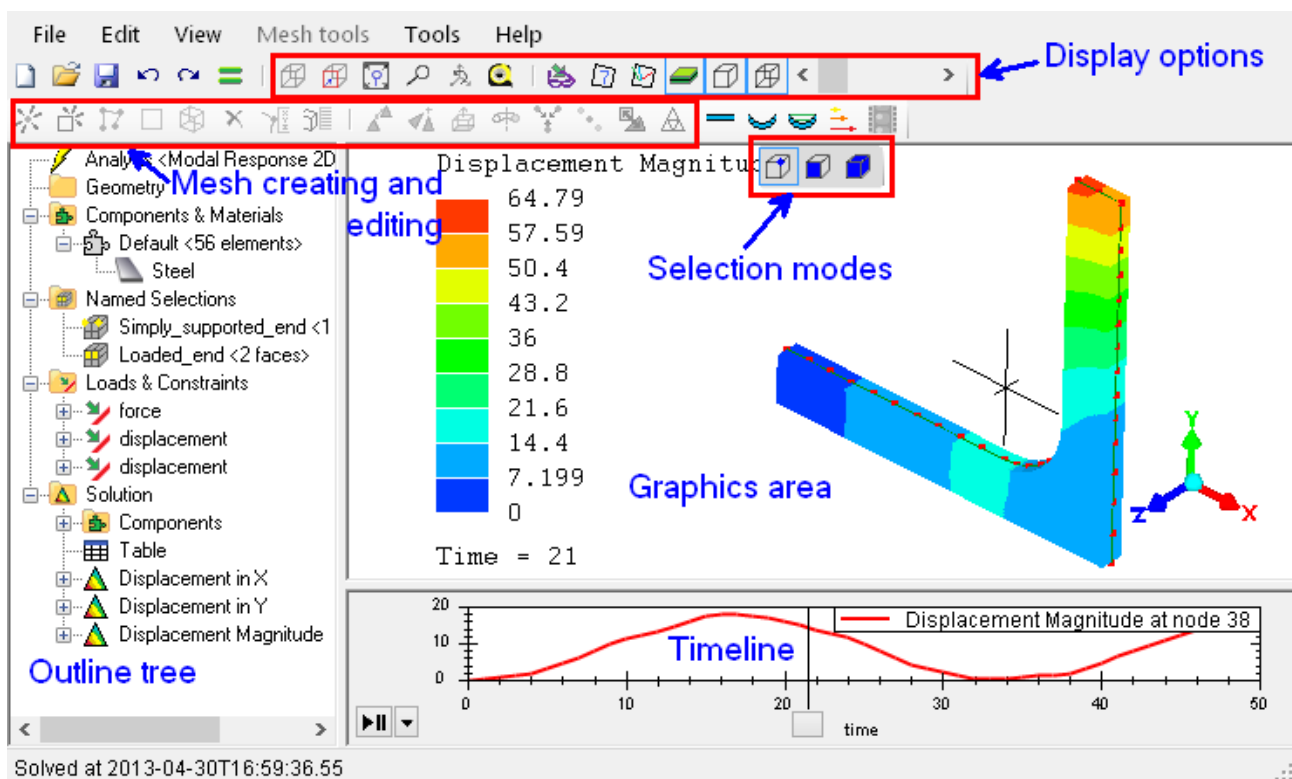

1.1 Mesh

A finite element mesh consists of nodes (points) and elements (shapes which link the nodes together). Elements represent material so they should fill the volume of the object being modeled. The mesh is displayed in the graphics area which occupies most of the LISA window.

You can edit a mesh using the **Mesh tools** menu or by selecting parts and using the right-click context menu to access the mesh editing tools.

The other contents of a model are shown in the outline tree on the left hand side of the window. It has several groups containing different types of item listed below. Most of these items can be modified through a context menu which you can access by right-clicking on them.

1.2 Analysis

You can change global properties such as analysis type, physical constants, solver settings and output options by editing the Analysis item in the outline tree

1.3 Geometry

If you generate a mesh from a STEP or IGES file exported from CAD then these files are shown in the Geometry group. Each geometry item can be auto-meshed to generate a mesh.

1.4 Components & Materials

A component is an exclusive collection of elements. Every element must belong to exactly one component. The default component is created automatically and cannot be deleted.

Components are used for assigning materials and controlling the appearance (color and visibility) of elements. All elements in a component share the same material and color. For complex models with logically different parts or features it can be helpful to assign each part to a component to aid in working on the mesh.

Each component containing some elements must have a material assigned to it. The same material can be shared between several components.

You can convert a component to a named selection by selecting its elements then creating a new element selection or adding them to an existing named selection. A named selection containing elements can be converted to a component in a similar way.

1.5 Named Selections

A named selection is a non-exclusive collection of nodes, elements or faces. A face is a face or edge of an element. Named selections are used for applying loads and constraints. For example, to apply a force to the surface of an object, instead of applying a separate force on every face in the surface, you would put all the faces in a named selection and apply a single force to the named selection.

1.6 Loads & Constraints

This group contains all the loads and constraints in the model. It can also contain load cases with their own loads. Loads which are applied to named selections show their named selections as child nodes in the outline tree.





1.7 Solution

After solving, the results are shown under the **Solution** branch in the outline tree. You can click on a field value to display a colored contour plot of it.

Viewing and Selecting

2.1 Zoom, Pan, Rotate

2.1.1 Tool buttons

-  Fit to screen
-  Use the left mouse button to zoom
-  Use the left mouse button to rotate
-  Rotate to isometric view
-  Rotate to orthogonal view

2.1.2 Keyboard

| | |
|-------------------------|-------------------------------------------|
| PgUp | Zoom-in |
| PgDn | Zoom-out |
| Arrow Keys | Pan up/down/left/right |
| Alt + Arrow Keys | Rotate |
| F8 | Fit to screen and rotate to isomeric view |

2.1.3 Mouse

| | |
|--------|----------------------------------------|
| Rotate | Drag the cursor with the middle button |
| Zoom | Rotate the mouse wheel |
| Pan | Drag the cursor with the right button |

2.1.4 Triad

The triad at the bottom right of the screen can be used to rotate the view parallel to the XY, YZ or ZX planes or isometrically.

Left click of the Z-axis
arrowhead

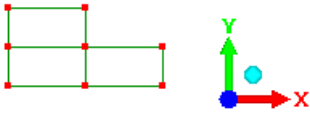

Right click of the
Z-axis arrowhead

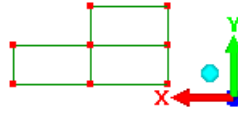

Click the cyan ball for
3D isometric view.

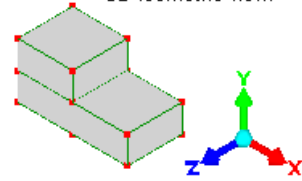

2.2 Display modes

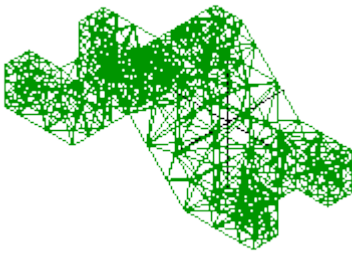

 Toggle the display of element
surfaces.

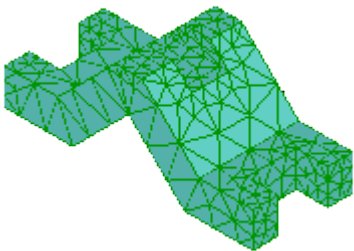
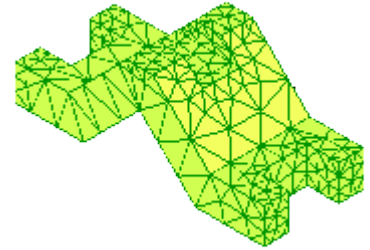

 Toggle element edge display.

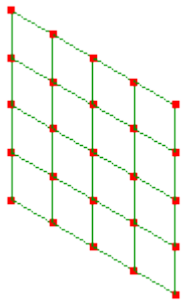

 Toggle shell thickness display when element surfaces
are displayed.

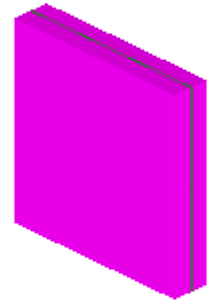

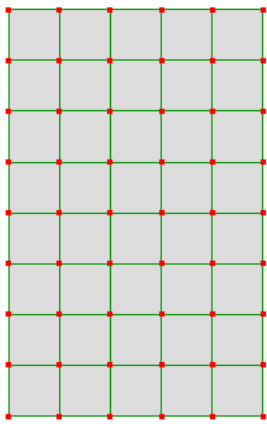

Open cracks in the **View** menu toggles this mode. It helps to show narrow gaps in the mesh where elements appear to be connected but are not sharing the same nodes. When open cracks mode is on, the outside surface of a mesh is shrunk, enlarging any gaps.

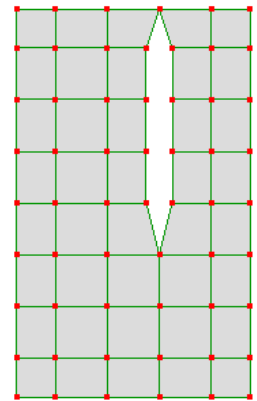

2.3 Selection

LISA is selection driven which means to perform most mesh editing tasks you first have to select nodes, element faces or entire elements.

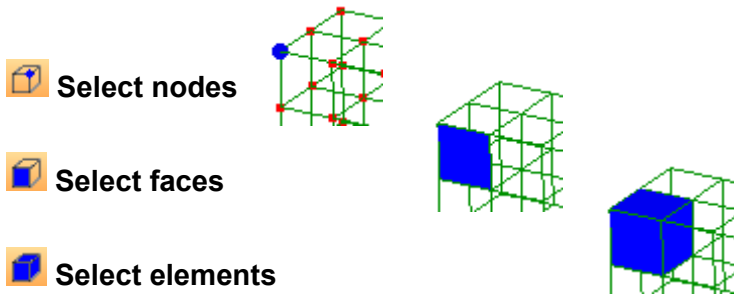

 **Select nodes**

 **Select faces**

 **Select elements**



Hold **Ctrl** while selecting to add or remove items from the selection.

Hold the **Shift** key to disable node dragging while selecting nodes with mouse.

2.3.1 Selection tutorial

Step 1

Open **SelectionTutorial.liml** from the tutorials folder where LISA has been installed.

Step 2

Click the X arrowhead of the triad  to switch to side view.

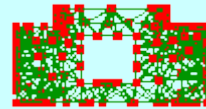

Activate **Select nodes** 

Drag the mouse over the entire mesh.

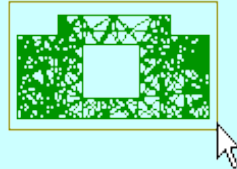

Rotate the model to observe that all the nodes have been selected even the ones hidden from view.

Click in the open space to deselect the model.

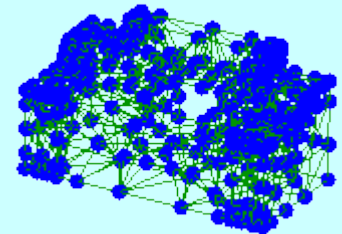

Step 3

Return to the side view.

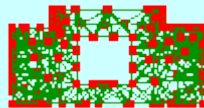

Activate **Select faces**  and drag the mouse over the entire mesh.

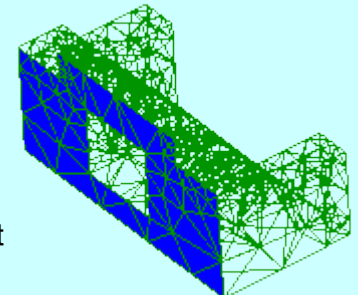
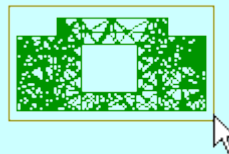

Rotate the model to see that the mesh hidden from view didn't get selected. Keep these faces selected for the next step.

Step 4

This face selection can be saved as a **Named Selection** which will be shown in the outline tree. Right click a selected face and click  **Add faces to new named selection**

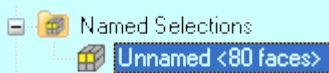

Click an empty space to deselect the faces. Then click the newly created **Unnamed<80 faces>** named selection to reselect these faces. Right click **Unnamed** to **Rename** it.

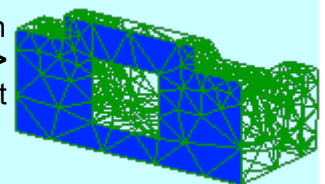

Step 5

To illustrate the effect of the **Ctrl** key, activate **Select faces**  and drag to select any section of the mesh. It doesn't need to look like this image.

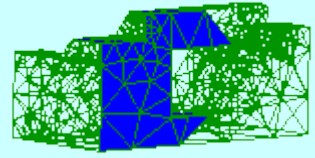

Hold the **Ctrl** key down and drag to select another area of the mesh. This new selection is added to the faces that were first selected.

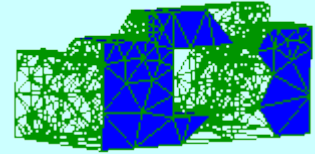

Hold the **Ctrl** key down and click any of the selected faces and they become unselected.

Chapter 3

Units

LISA doesn't use any system of units itself. You must apply consistent units to all quantities. This table shows 8 examples of consistent unit systems. Four of these are expanded in more detail in the subsequent table.

| | SI | | | MMGS | FPS | | IPS | |
|--------|----|----|----|------|-----------------|------------------------------------|-------------------------------------|------------------------------------|
| Length | m | mm | mm | mm | ft | ft | in | in |
| Mass | kg | kg | Mg | g | slug | lb _M | lb _F ·s ² /in | lb _M |
| Force | N | mN | N | μN | lb _F | lb _M ·ft/s ² | lb _F | lb _M ·in/s ² |
| Time | s | s | s | s | s | s | s | s |

Note that lb_M (pound-mass) and lb_F (pound-force) are usually not consistent with each other. In the IPS system, density has units of lb_F·s²/in⁴, not lb_M/in³. If you know a density value in terms of lb_M/in³, you need to convert it to lb_F·s²/in⁴ by dividing it by standard gravity, 32.174×12in/s². For example if the density is 0.283 lb_M/in³ you would use .000733 lb_F·s²/in⁴ in LISA.

| | | SI m, kg, s, A, K | MMGS mm, g, s | FPS ft, lb _F , s | IPS in, lb _F , s |
|-------------------|--------------------------------------|----------------------|------------------------------------------------------------|--------------------------------------------------------------|--------------------------------|
| Mechanical | Displacement | | | | |
| | Length | m | mm | ft | in |
| | Force | N | μN | lb | |
| | Moment per length (MomentU, etc.) | kg·m/s ² | g·mm/s ² | | |
| | Shear force | | | slug | slinch |
| | Mass | kg | g | lb·s ² /ft | lb·s ² /in |
| | Pressure | | | | |
| Stress | | | | | |
| Force per area | Pa | | lb/ft ² | psi | |
| Young's modulus | J/m ³ | | | lb/in ² | |
| Shear modulus | kg·m ⁻¹ ·s ⁻² | | | | |
| Shear flexibility | g·mm ⁻¹ ·s ⁻² | | | | |
| Energy density | | | | | |
| Density | kg/m ³ | g/mm ³ | slug/ft ³ lb·s ² /ft ⁴ | slinch/in ³ lb·s ² /in ⁴ | |
| Area density | kg/m ² | g/mm ² | slug/ft ² lb·s ² /ft ³ | slinch/in ² lb·s ² /in ³ | |

| | | | | | |
|-----------------|-------------------------------------------------------------------------------------|------------------------------------------------------------------------------------------------------------------------------------|--------------------------------------------------------------------------|---------------------------------------------------------------|------------------------------------------------------|
| | Moment Torsion | N.m kg.m ² /s ² | μN.mm g.mm ² /s ² | ft.lb | in.lb |
| | Shear force per length Force per length Tension per length Spring constant | N/m kg/s ² | μN/mm g/s ² | lb/ft | lb/in |
| | Area | m ² | mm ² | ft ² | in ² |
| | Velocity Speed | m/s | mm/s | ft/s | in/s |
| | Angular velocity | radian/s | | | |
| | Acceleration | m/s ² | mm/s ² | ft/s ² | in/s ² |
| | Heat transfer rate | W kg.m ² s ⁻³ | nW g.mm ² s ⁻³ | ft.lb/s | in.lb/s |
| | Rotational inertia | kg.m ² | g.mm ² | slug.ft ² lb.ft.s ² | lb.in.s ² |
| | Pressure gradient (dP/dX) | Pa/m kg.s ⁻² m ⁻² | Pa/mm g.s ⁻² mm ⁻² | lb/ft ³ | lb/in ³ |
| | Heat flux | W/m ² kg.s ⁻³ | nW/mm ² g.s ⁻³ | lb.s ⁻¹ ft ⁻¹ | lb.s ⁻¹ in ⁻¹ |
| | Power density Internal heat source | W/m ³ nW/mm ³ kg.s ⁻³ m ⁻¹ g.s ⁻³ mm ⁻¹ | | lb.s ⁻¹ ft ⁻² | lb.s ⁻¹ in ⁻² |
| | Flow rate | m ³ /s | mm ³ /s | ft ³ /s | in ³ /s |
| | Velocity potential | m ² /s | mm ² /s | ft ² /s | in ² /s |
| | Vorticity | s ⁻¹ | | | |
| | Dynamic viscosity | Pa.s kg.m ⁻¹ s ⁻¹ g.mm ⁻¹ s ⁻¹ | | slug.ft ⁻¹ s ⁻¹ lb.s/ft ² | lb.s/in ² |
| | Consistency index K | Pa.s ⁿ Ns ⁿ /m ² kg.s ⁿ⁻² m ⁻¹ g.s ⁿ⁻² mm ⁻¹ | | lb.s ⁿ /ft ² | lb.s ⁿ /in ² |
| | Temperature | K | K | °R | °R |
| | Heat transfer coefficient | W.m ⁻² K ⁻¹ kg.s ⁻³ K ⁻¹ | nW.mm ⁻² K ⁻¹ g.s ⁻³ K ⁻¹ | lb.s ⁻¹ ft ⁻¹⁰ F ⁻¹ | lb.s ⁻¹ in ⁻¹⁰ F ⁻¹ |
| | Stefan-Boltzmann constant | Wm ⁻² K ⁻⁴ kg.s ⁻³ K ⁻⁴ | nW.mm ⁻² K ⁻⁴ | n/a | n/a |
| | Thermal expansion coefficient | K ⁻¹ | | °F ⁻¹ | °F ⁻¹ |
| | Thermal conductivity | W.m ⁻¹ K ⁻¹ kg.m.s ⁻³ K ⁻¹ | nW.mm ⁻¹ K ⁻¹ | lb.s ⁻¹⁰ F ⁻¹ | lb.s ⁻¹⁰ F ⁻¹ |
| | Specific heat | J.kg ⁻¹ K ⁻¹ m ² K ⁻¹ s ⁻² | nJ.g ⁻¹ K ⁻¹ | ft ² s ⁻²⁰ F ⁻¹ | in ² s ⁻²⁰ F ⁻¹ |
| Electromagnetic | Voltage | V m ² kg.s ⁻³ A ⁻¹ | nV mm ² g.s ⁻³ A ⁻¹ | | |
| | Electric current | A | | | |
| | Electric charge | C A.s | | | |
| | Current density | A/m ² | A/mm ² | | |
| | Electric field | V/m m.kg.s ⁻³ A ⁻¹ | nV/mm mm.g.s ⁻³ A ⁻¹ | | |

| | | | |
|---------------------------------------------------------------------------------|----------------------------------------|------------------------------------------|--|
| Electric flux density | $\frac{C}{m^2}$ $\frac{A.s}{m^2}$ | $\frac{C}{mm^2}$ $\frac{A.s}{mm^2}$ | |
| Magnetic potential Magnetic flux lines | $\frac{Wb}{m}$ $m.kg.s^{-2} A^{-1}$ | $\frac{nV.s}{mm}$ $mm.g.s^{-2}A^{-1}$ | |
| Magnetic flux density B | $\frac{T}{kg.s^{-2} A^{-1}}$ | $\frac{mT}{g.s^{-2}A^{-1}}$ | |
| Magnetic field intensity H | $\frac{A}{m}$ | $\frac{A}{mm}$ | |
| Absolute permittivity | $\frac{F}{m}$ $m^{-3}kg^{-1}s^4A^2$ | $\frac{GF}{mm}$ $mm^{-3}g^{-1}s^4A^2$ | |
| Absolute permeability | $\frac{H}{m}$ $m.kg.s^{-2}A^{-2}$ | $\frac{nH}{mm}$ $mm.g.s^{-2}A^{-2}$ | |
| Electrical conductivity | $\frac{S}{m}$ $m^{-3}kg^{-1}s^3A^2$ | $\frac{GS}{mm}$ $mm^{-3}g^{-1}s^3A^2$ | |
| Resistance | $\frac{\Omega}{m^2kg.s^{-3}A^{-2}}$ | $\frac{n\Omega}{mm^2g.s^{-3}A^{-2}}$ | |
| Node rotational DOF angle | radian | | |
| Node transform angle Angle for principal stress | ° | | |
| Height gradient (dZ/dX) Emissivity Poisson ratio Flow behavior index n | dimensionless | | |

Mesh Creation

4.1 Manual meshing

LISA supplies tools for creating models without the use of a CAD file.

4.1.1 Essential tools

The following tools can be used for manual meshing.

a. Quick square / Quick cube

To test a LISA feature you will often create a quick shell or solid element  with unit dimensions.

Mesh tools → **Create** → **Quick square** and

Mesh tools → **Create** → **Quick cube**



b. Create a node

Use **Mesh tools** → **Create** → **Node...** to create a node by specifying its X,Y & Z co-ordinates 

c. Create an element

Use **Mesh tools** → **Create** → **Element...** or  to create an element either by selecting the nodes using the mouse or entering a list of node numbers. Don't select the nodes haphazardly, but follow the number sequence shown in the diagram on the dialog box.

d. Create a circle / arc

Use **Mesh tools** → **Create** → **Curve generator...**  **Ellipse** for circle and  **Center and start point arc** for arc. The **Center and start point arc** requires an angle less than 180°. For a 180° or greater arc use the **Three point arc**  **Three point arc**

e. Create a line

Use the **Mesh tools** → **Create** → **Curve generator...**  **Straight line** or create the end nodes and then create a single element over that length, then use the refine tool to convert it into multiple elements.

f. Create a curve defined by equations

Use the **Mesh tools** → **Create** → **Curve generator...** and enter parametric equations for X, Y and Z in terms of the parameter p. Specify the interval for p and the number of elements to create.

g. Move

Mesh tools → **Move/Copy...** to translate elements or nodes. It can create a copy of the original mesh or just move it.

h. Rotate

Mesh tools → **Rotate/Copy...** to rotate elements or nodes. It can create a copy of the original mesh or just move it.

i. Mirror

Mesh tools → **Mirror/Copy...** to mirror elements or nodes about the XY, YZ or ZX planes, or about a point defined by a node's location. It can create a copy of the original mesh or just move it.

j. Eliminating duplicate nodes

Duplicate nodes are often a by-product of meshing operations and need to be removed. Use **Mesh tools** → **Merge nearby nodes...**, type in a small radius within which the duplicate nodes are to be replaced by a single node. Too small a value may not eliminate all duplicates and too large a value will collapse elements (if two or more nodes of the same element are replaced by a single node, the element collapses). Start with a very small value such as 0.00001 and use the **View** → **Open cracks** to check if gaps are still present.

If some nodes are selected before using this tool then only the selected nodes will be considered. However if you check **Merge other nodes into selected nodes** then the selected nodes will not be moved but any other nodes within the tolerance distance will be merged with them.

k. Eliminating unused nodes

Deleted elements may leave behind nodes. Any that are not re-used should be eliminated using **Mesh tools** → **Delete unused nodes**.

l. Deleting items

To delete elements, first select them or any of their faces then press **Del**. This will also delete any unused nodes left behind. To delete elements without deleting their nodes press **Ctrl + Del**.

To delete a component along with all its elements and their nodes, right click the component in the outline tree and select **Delete**.

To delete nodes, first select the nodes then press **Del**.

4.1.2 Essential tools tutorial

Step 1

Mesh tools → Create → Curve generator...

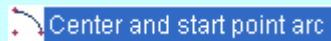

Center 0,0,0
 Start Point 5,0,0
 End Point 0,5,0
 Number of Nodes 6

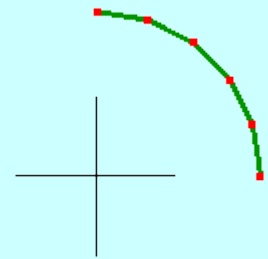

Step 2

Mesh tools → Create → Curve generator...

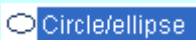

D1 20
 D2 20
 x 0

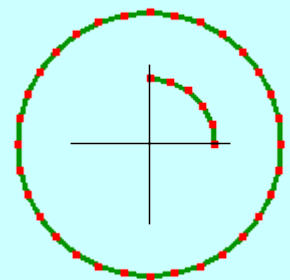

Step 3

Activate the **Select nodes** mode

then select the nodes shown by dragging the mouse. Hold the **Ctrl** key down to add to the already selected nodes.

Then press the **Del** key.

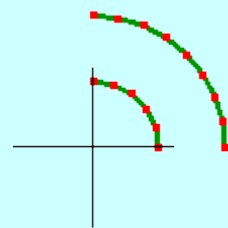
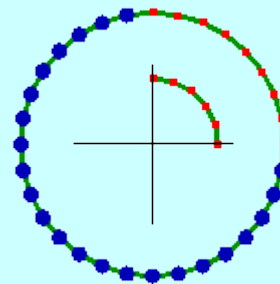

Step 4

Select **Mesh tools** → **Create** → **Element...** or click and choose **line2 beam/truss**

Click these two nodes

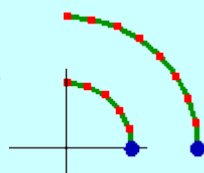

next click these nodes

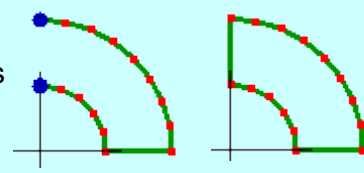

Step 5

Mesh tools → Automesh 2D...

Maximum element size 1

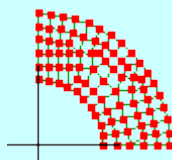

Step 6

Drag and select all the nodes

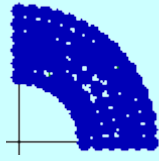

Mesh tools → **Rotate/Copy...**

Rotation about point

0,0,0

Specify rotation angles around X,Y,Z axis in degrees

0,0,90

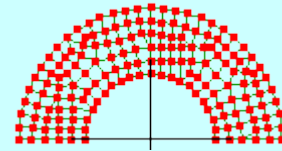

Check **Copy**

In this particular illustration the nodal patterns at the mating edge do line up, however, it will not always be so with meshes generated by the automesh. The automesh should be used to create an entire mesh rather than a section for duplicating to build up the rest of the mesh.

Step 7

Drag and select all the nodes

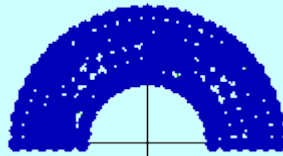

Mesh tools → **Mirror/Copy...**

Mirror plane **ZX plane**

Check **Copy**

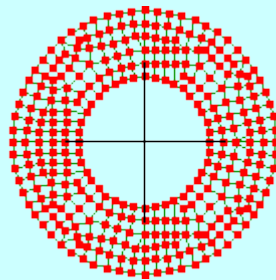

Step 8

View → **Open cracks**

The gaps mean that the mesh is not continuous.

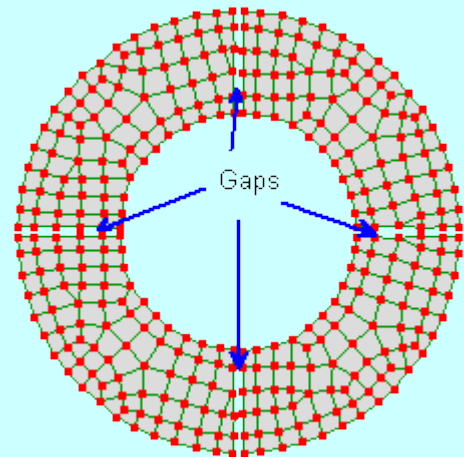

Mesh tools → **Merge nearby nodes...**

Distance tolerance 0.00001

View → **Open cracks**

It's now a continuous mesh.

Step 9

Edit → Circle selection

Don't worry if your selection doesn't look exactly like this. The purpose is to select two rows of nodes.

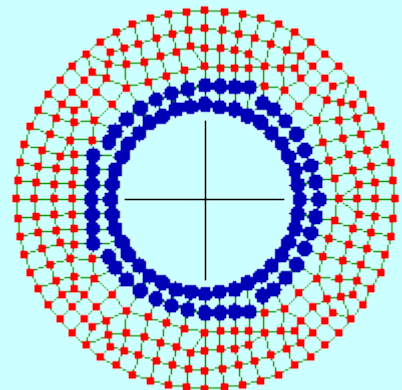

Hold the **Ctrl** key down and deselect the nodes on the inner diameter while leaving the second row of nodes as selected.

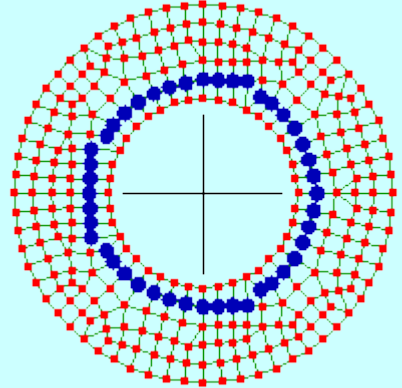

Press the **Del** key

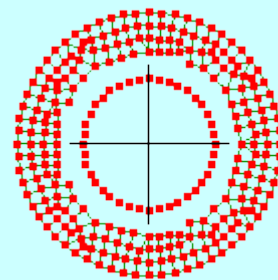

Mesh tools → Delete unused nodes

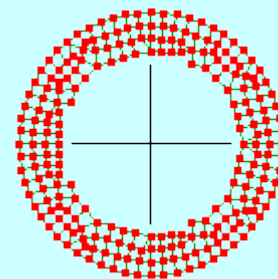

4.1.3 Manual meshing work-flow

Use 2 node line elements to lay out the boundary of a 2D planar area and any holes. The 2D automeshing will mesh everything including the holes, so the elements within the holes will need to be

deleted afterwards. The reason it fills holes is so that shaped areas can be extruded or revolved to create 3D meshes.

2D meshing tutorial

Step 1

Open **2dMeshingTutorial.liml** from the tutorials folder where LISA has been installed.

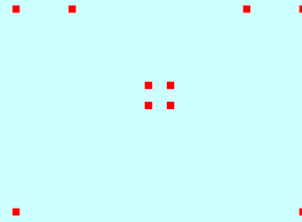

Step 2

Mesh tools → **Create** → **Element...** or 

Select **line2** **beam/truss**

Click the nodes to form the following profile.

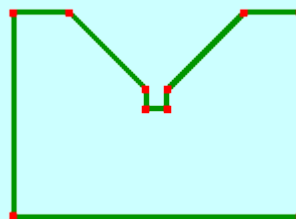

Step 3

Mesh tools → **Automesh 2D...**

Maximum element size 10

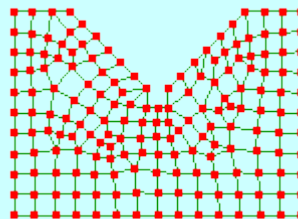

4.1.4 3D manual meshing

Once a 2D plane mesh has been created it can be extruded, revolved or lofted to create a 3D model.

4.1.5 Extrude

Extrusions can only be done on faces. Select faces using **Select faces** 



Line elements and shell edge faces extrude into shells



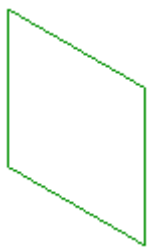

Shell or solid faces

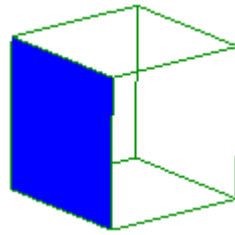

extrude into solids

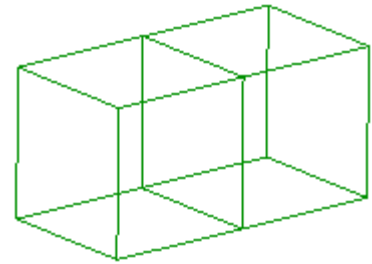

Extrude tutorial

Step 1

Open **ExtrudeTutorial.liml** from the tutorials folder where LISA has been installed.

Step 2

Activate **Select faces** 

Drag the mouse over the entire mesh so that it becomes selected.

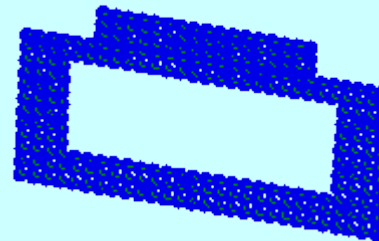
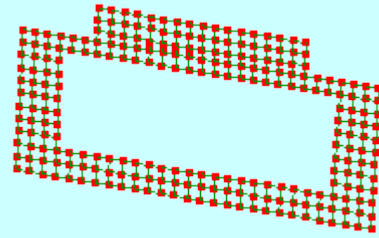

Step 3

Mesh tools → **Extrude...**

Thickness 5

Number of subdivisions 3

Direction +Z

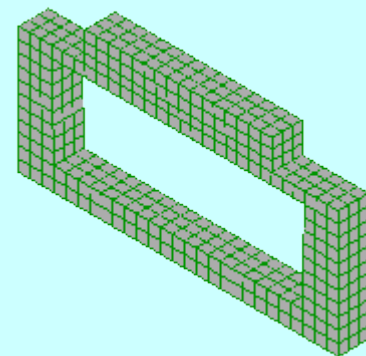

Step 4

The extrusion step turned off **Select faces** so reactivate it again.

Select the faces at the bottom.

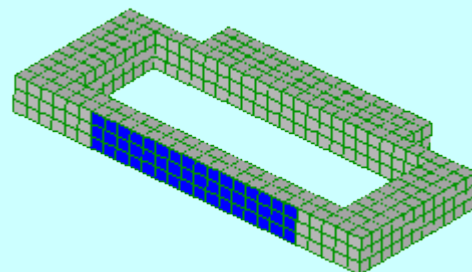

Mesh tools → Extrude...

Thickness 5
Number of subdivisions 3
Direction +Normal

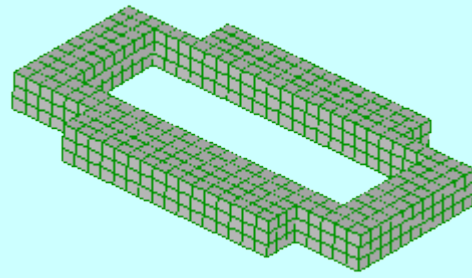

4.1.6 Revolve

Revolve can only be used on faces. Select faces using **Select faces** 

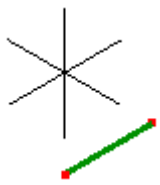

Line elements and shell edge faces revolve into shells

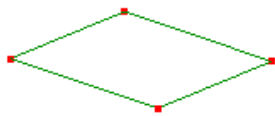
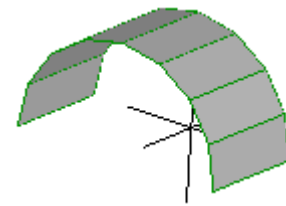

Shell or solid faces

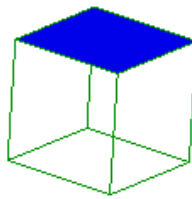

revolve into solids

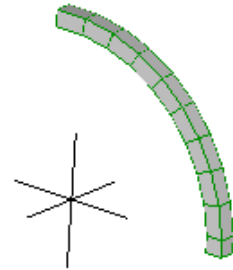

Revolve tutorial

Step 1

Open **RevolveTutorial.liml** from the tutorials folder where LISA has been installed.

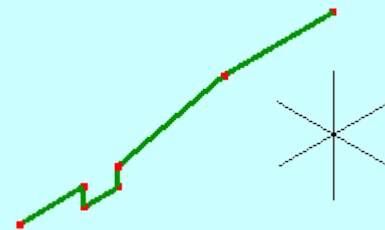

Step 2

Activate **Select faces** 

Drag the mouse over the entire mesh so that it becomes selected.

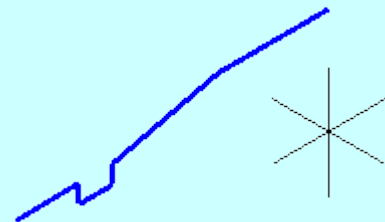

Mesh tools → Revolve...

| | |
|-------------------------------|-----|
| Angle | 360 |
| Number of subdivisions | 12 |
| Axis of revolution | +Z |

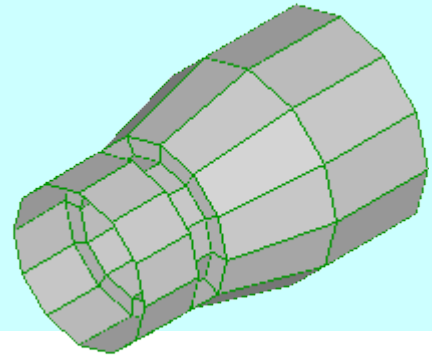

4.1.7 Hollow

The hollow tool will convert a solid mesh into shells. If no elements or nodes are selected then it will use the entire mesh.

Sectional view showing solid elements.

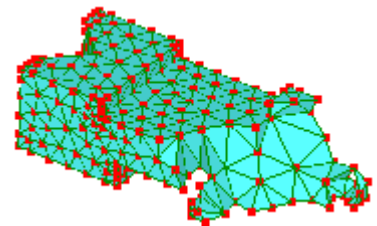

Sectional view after using the hollow tool.

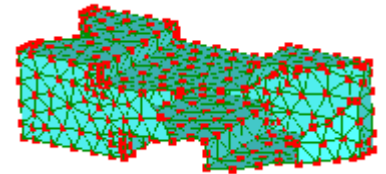

4.1.8 Loft

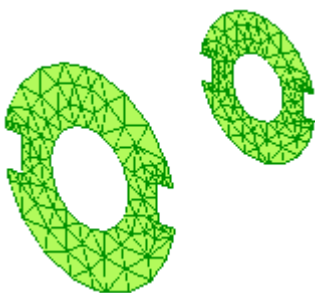

The loft tool fills the gap between two profiles having matching nodal patterns with solid elements. This can be used for creating tapered parts. The order of the node numbers must be identical on each profile with the only difference being a constant offset.

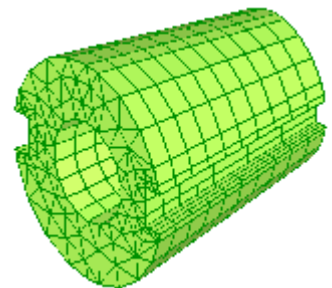

Loft tutorial

Step 1

Open **LoftTutorial.liml** from the tutorials folder where LISA has been installed.

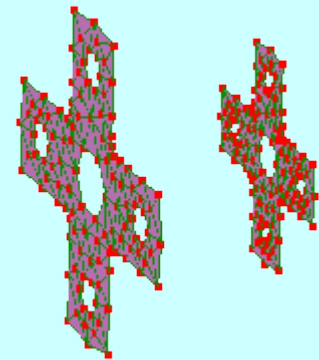

Step 2

Display node and element numbers. 

Note down the node numbers of any two corresponding nodes on each profile. In this example the bottom corner node numbers are 12 and 135.

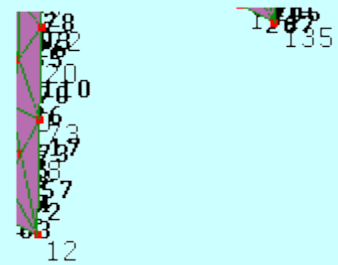

Step 3

Activate **Select faces**. 

Drag to select the profile of node number 135.

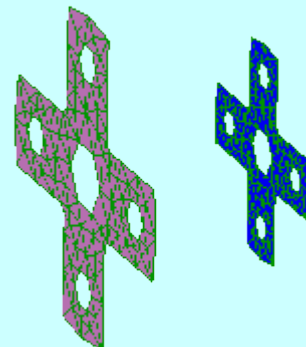

Step 4

Mesh tools → **Loft...**

Number of subdivisions 4

A node in selected faces 135

The corresponding node 12

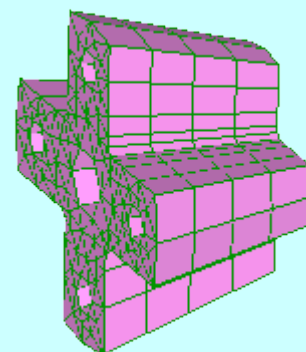

4.1.9 Changing element shapes

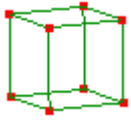

Elements with mid-side nodes converge faster.

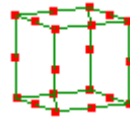

Mesh tools → Change element shapes...

4.2 Symmetry

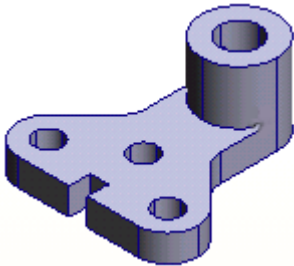

If the geometry, loads & constraints are symmetric (*mirror symmetry*), a model size can be reduced to half or quarter.

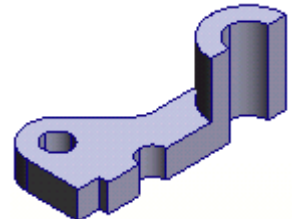

When taking advantage of *mirror symmetry* you must enforce constraints at the plane of symmetry. In static analysis the nodes in the plane of symmetry must be constrained so that they do not move out of that plane otherwise a gap or penetration will occur which in reality is not present in the full model. For elements with rotational degrees of freedom like shells and beams, each node that lies in the plane of symmetry should be constrained to have no rotation about either of the two axes that also lie in the plane of symmetry. In thermal analysis there should be no heat flow across a plane of symmetry, which is a condition that is automatically enforced where no other boundary conditions are specified. The same concept extends to fluid, magnetostatic, DC current flow and electrostatic analyses.

Take care when assuming mirror symmetry for modal vibration or buckling problems because non-symmetric modes will be missed.

Cyclic symmetry which occurs in turbines, fans, etc can be taken advantage of by modeling only a segment containing the cyclic feature rather than the whole wheel. The node patterns must match on both sides of the segment.

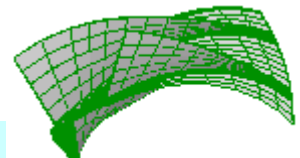

4.2.1 Mirror symmetry tutorial

Step 1

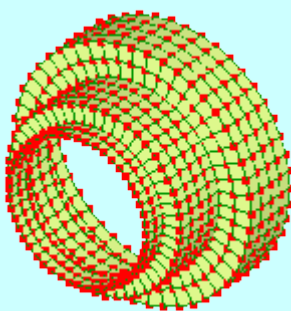

This revolved shell can be modeled as only one quadrant.

Open **MirrorSymmetryTutorial.liml** from the tutorials folder where LISA has been installed.

Step 2

The quarter segment's vertical plane of symmetry is the XY plane and its horizontal plane of symmetry is the ZX plane. Its axis of revolution is the X-axis.

Activate **Select nodes** 

Select the nodes lying in the vertical plane of symmetry. Constraints need to be applied to keep these nodes from moving out of the XY plane, while allowing them the freedom to move within the XY plane.

Right click the selected nodes

Loads & constraints → **New displacement**

Axis X

Value 0

Since shell nodes have rotational degrees of freedom, the nodes in the XY plane must be prevented from rotating about the X and Y axes.

Right click on the selected nodes again

Loads & constraints → **On Selected Nodes** → **New rotx**

Value 0

Repeat for **roty**.

Step 3

While still in **Select nodes**  mode, select the nodes lying in the horizontal plane of symmetry. Constraints need to be applied to keep these nodes from moving out of the ZX plane or rotating about any axis lying in that plane.

Right click on the selected nodes

Loads & constraints → **New displacement**

Axis X

Value 0

Right click on the selected nodes again

Loads & constraints → **On Selected Nodes** → **New rotx**

Value 0

Repeat for **roty**.

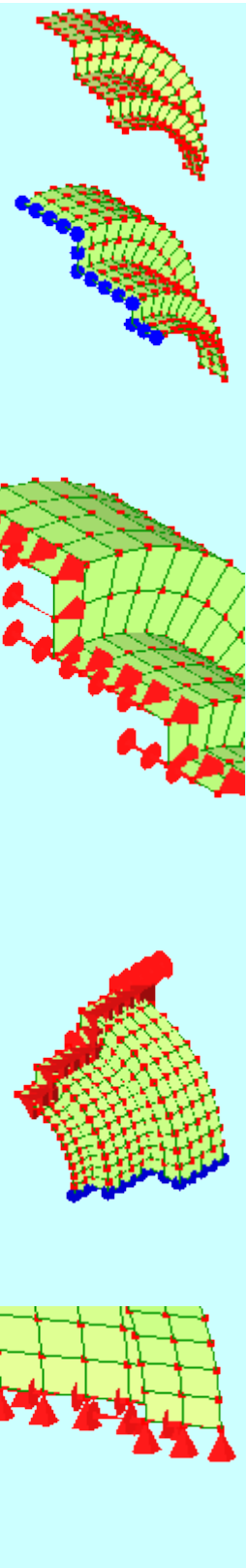

4.3 Mesh refinement

Finite element meshes need to be refined until the results no longer change by more than a small percentage value, at which point the results are said to have **converged** and no advantage would be gained by any further mesh refinement.

4.3.1 Refine all

Mesh tools → **Refine** → **x2** or  will replace every element in a model with smaller elements.

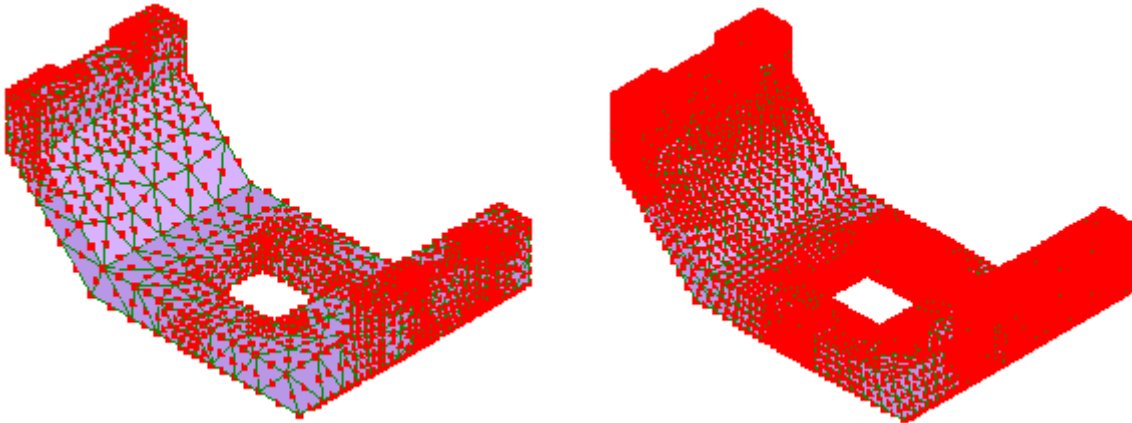

Or, to replace an existing mesh with a new mesh with controlled element size and local refinement, use **Mesh tools** → **Automesh 3D** for 3D meshes or **Mesh tools** → **Automesh 2D** for 2D meshes that lie in the X-Y plane.

4.3.2 Refine local 2D & shell

The **Mesh tools** → **Refine** → **Quad local refinement x2** and **Mesh tools** → **Refine** → **Quad local refinement x3** are used in the same way, the only difference being that x2 is a coarser refinement than x3. The limitation to using this command is that the elements must be 4 node quadrilaterals (quad4) and not triangles.

If the bounding area for refinement includes triangles, the quadrilaterals around the triangles will be refined but not the triangles. This will lead to the mesh error of refined nodes lying on an element edge instead of being connected node-to-node. A node on element edge is no connection at all. One option could be to use the **Mesh tools** → **Change element shape...** to first convert all the quadrilaterals into triangles and then repeat this command to convert all the triangles to quadrilaterals. A drawback of this procedure is that the quadrilateral shapes will be severely distorted.

Refine local 2D & shell tutorial

Step 1

Open **RefineLocal2dTutorial.liml** from the tutorials folder where LISA has been installed.

Step 2

Drag the mouse to select the nodes shown below. Don't worry if you selected a few extra nodes, this is only an illustration.

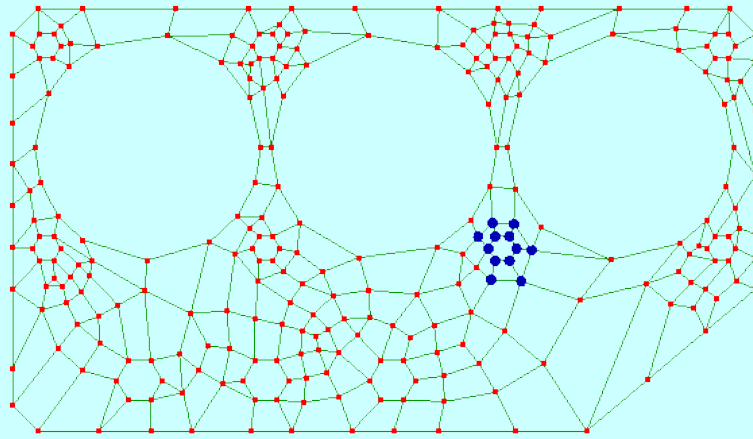

Step 3

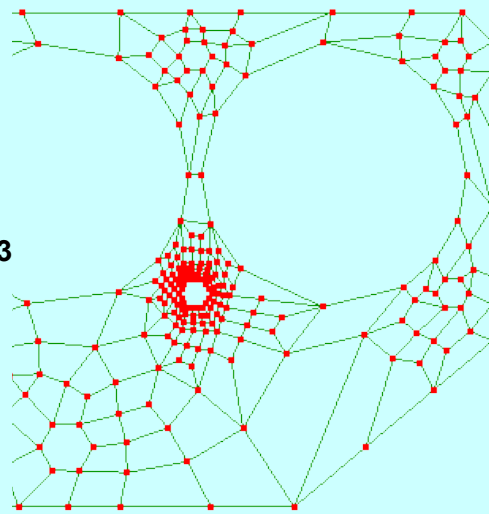

Mesh tools → Refine → Quad local refinement x3

4.4 Mesh information

4.4.1 Volume

Tools → **Volume** will report the volume of selected elements. If no elements are selected, it will report the full mesh volume.

4.4.2 Surface area

Tools → **Surface area** reports the area of selected faces.

4.4.3 Length

 Activate the tape measure tool, click and drag from one node to another.

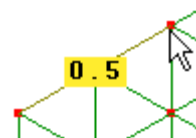

4.4.4 Nodal co-ordinates

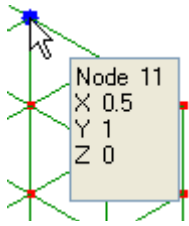

Click a node for a readout of its co-ordinates.

4.5 Modeling errors

Results can only be as accurate as your model. Use rough estimates from hand calculations, experiment or experience to check whether or not the results are reasonable. If the results are not as expected, your model may have serious errors which need to be identified.

4.5.1 Too coarse a mesh

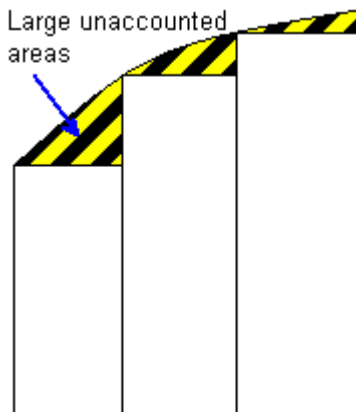

To illustrate the effect of mesh refinement on accuracy, consider the case of finding the area under a curve by the summation of rectangular areas contained within the curve. Clearly, the narrower the rectangles, the more accurate will be the result.

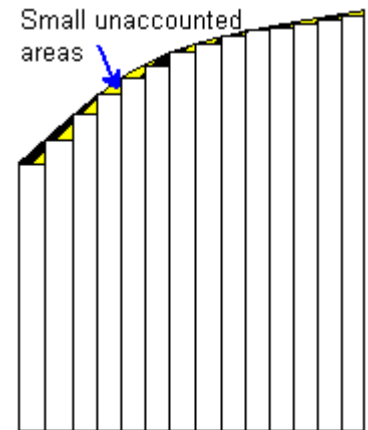

An efficient way of refining a mesh is to concentrate the mesh refinement in those areas where the accuracy can be improved, while leaving unchanged those areas that are already accurate.

You will have to run at least one model to identify the areas where the values are changing a lot and the areas where values are remaining more or less the same. The second run will be your refined model.

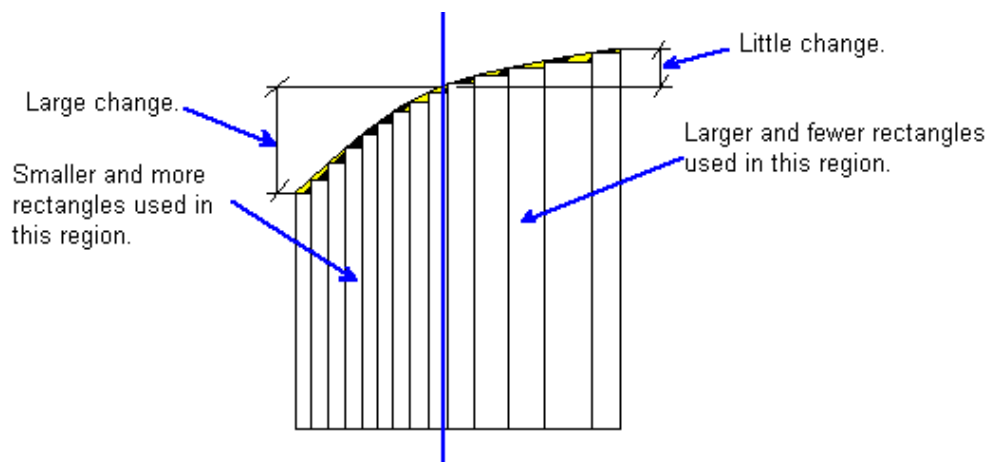

Refine areas that see large changes in value. Do not refine areas where values are more or less the same; it will only bloat the size of the model.

4.5.2 Wrong choice of elements

Bending problems with plate-like geometries such as walls, where the thickness is less in comparison to its other dimensions, should be modeled with either shell elements or quadratic solid elements like the 20 node hexahedron or the 10 node tetrahedron. Shell, beam and membrane elements should not be used where their simplified assumptions do not apply. For example beams that are too thick, membranes that are too thick for plane stress and too thin for plane strain, or shells that are initially twisted out of their plane. In each of these cases solid elements should be used.

4.5.3 Linear elements



Linear elements (elements with no mid-side nodes) are too stiff in bending so they typically have to be refined more than quadratic elements (elements with mid-side nodes) for results to converge.

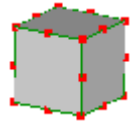

4.5.4 Severely distorted elements

Element shapes that are compact and regular give the greatest accuracy. The ideal triangle is equilateral, the ideal quadrilateral is square, the ideal hexahedron is a cube of equal side length, etc. Distortions tend to reduce accuracy by making the element stiffer than it would be otherwise, usually degrading stresses more than displacements. All the elements in the LISA element library are isoparametric, where a parametric coordinate system is used along the form of the element. Thus, slight to moderate distortions do not have an appreciable effect on the accuracy of the elements. The reality is that shape distortions will occur in FE modeling because it is quite impossible to represent structural geometry with perfectly shaped elements. Any deterioration in accuracy will only be in the vicinity of the badly shaped elements and will not propagate through the model (St. Venant's principle). These artificial disturbances in the field values should not be erroneously accepted as actually being present.



Avoid large aspect ratios. A length to breadth ratio of generally not more than 3.

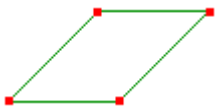

Highly skewed. A skewed angle of generally not more than 30 degrees.

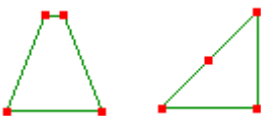

A quadrilateral should not look almost like a triangle.

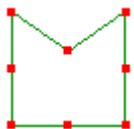

Avoid strongly curved sides in quadratic elements.

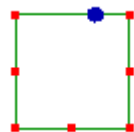

Off center mid-side nodes.

4.5.5 Mesh discontinuities

Element sizes should not change abruptly from fine to coarse. Rather they should make the transition gradually.

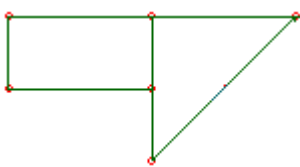
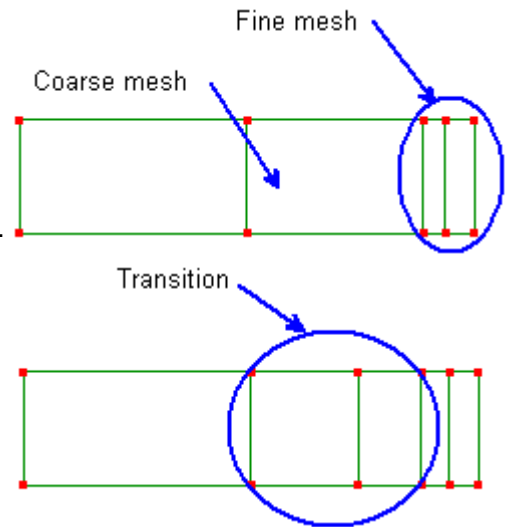

Nodes cannot be connected to element edges. Such arrangements will result in gaps and penetrations that do not occur in reality.

Linear elements (no mid-side node) should not be connected to the mid-side nodes of quadratic elements, because the edge of the quadratic element deforms quadratically whereas the edges of the linear element deform linearly.

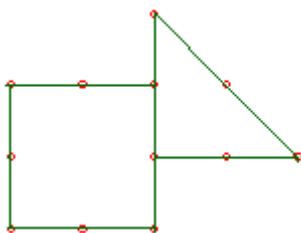
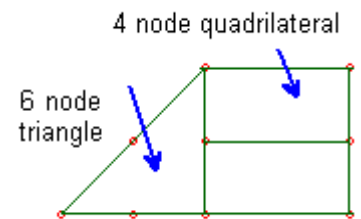

Corner nodes of quadratic elements should not be connected to mid-side nodes. Although both edges deform quadratically, they are not deflecting in sync with each other.

Avoid using linear elements with quadratic elements as the mid side node will open a gap or penetrate the linear element.

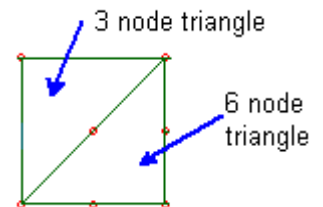

None of these is a fatal error. Each will simply cause discontinuities in the results which should not be mistaken as being present in the actual part. These effects will be localized and not propagate through the mesh.

4.5.6 Non-linearities

LISA can model only the linear portion of the stress-strain curve. Another kind of non-linearity which LISA cannot model is large deformations where the stiffness or load changes with deformation.

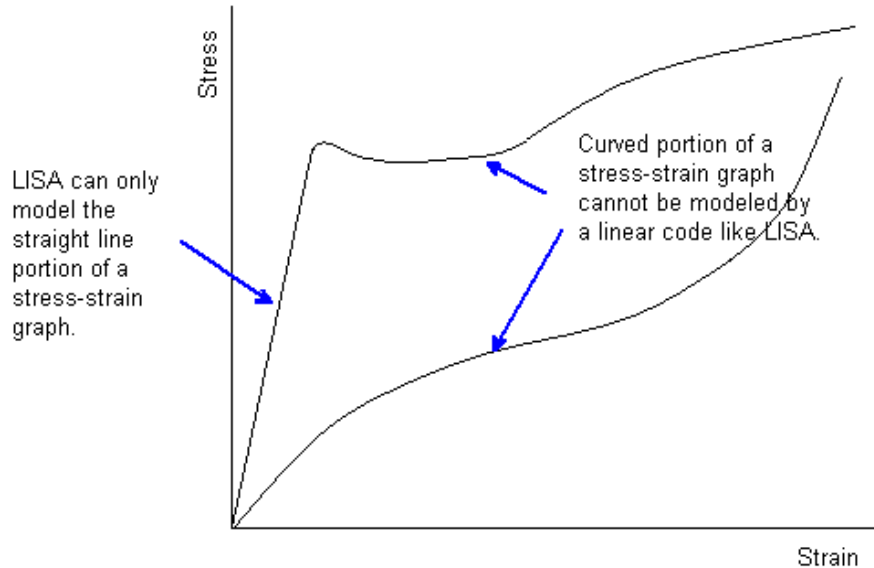

Shell elements under bending loads should not deform by more than half their thickness otherwise non-linear membrane action occurs in the real world to resist further bending. LISA cannot model resistance due to membrane action.

4.5.7 Improper constraints

Fixed supports will result in less deformation than simple supports which permit material to move within the plane of support.

4.5.8 Rigid body motion

In static analysis, for a structure to be stressed all rigid body motion must be eliminated. For 2D problems there are two translational (along the X- & Y-axes) and one rotational (about the Z-axis) rigid body motions. For 3D problems there are three translational (along the X-, Y- & Z-axes) and three rotational (about the X-, Y- & Z-axes) rigid body motions.

Rigid body motion can be eliminated by applying constraints such as **fixed support**, **displacement** and **rotx**, **roty** and **rotz**.

Modal vibration, dynamic response and modal vibration do not need to have all their rigid body motions eliminated. However the first few modes would be rigid body modes. For example, if you don't apply any constraints in a 3D modal vibration problem then the first 6 modes would be for the 6 rigid body motions. The 7th mode onwards would be the structure's deformation modes.

CAD Models

5.1 Introduction

LISA can open STEP and IGES files which can be output by most CAD applications. It doesn't display the parts but can generate a mesh of them (automesh). Links to CAD models appear in the **Geometry** group in the outline tree. Each geometry item in this group must contain a single solid body so you cannot use assemblies.

IGES files usually have disconnected edges and cannot give a continuous auto-meshed model. Also, LISA cannot generate a volume mesh from an IGES file, so only the **Surface mesh** option is enabled in the **Mesh parameters** dialog box. Volume mesh Surface mesh

STL (stereolithography) format files can also be opened and saved by LISA. An STL file only contains a set of triangles so these are imported as tri3 elements in LISA without any auto-meshing. Typically, STL files generated by CAD applications contain highly distorted elements so you should use **Automesh 3D** from the **Mesh tools** menu to improve the shape and convert the shells into a solid object.

When you first automesh a geometry item, a component is created for its elements and a named selection is created for each of its surfaces. These named selections are convenient for applying loads and constraints to because they are linked to the geometry item so that it can be auto-meshed again without losing the loads and constraints.

Meshing parameters allow local or global refinement by limiting the maximum element size within spherical regions or over the whole geometry. The size gradient of elements can also be controlled. An aggressive size gradient means each element can be much larger or smaller than its immediate neighbors leading to a low mesh density in large featureless regions and a high density near small details. A gradual size gradient means each element must be a similar size to its immediate neighbors.

To generate a shell mesh, use a solid body as the geometry and set the **Surface mesh** option. This will produce shell elements in the shape of the solid body's surface.

5.1.1 CAD Work-flow tutorial

Step 1

Use **File** → **Open** or right click  **Geometry** and select **Import STEP/IGES files**

Open the file **CadWorkflowTutorial.stp** from the tutorials folder where LISA has been installed

Step 2

Right click the file name and select **Generate Mesh**

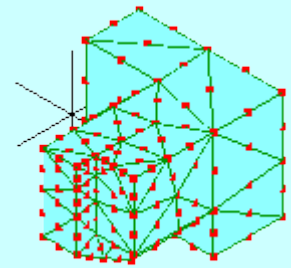
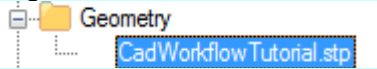

Step 3

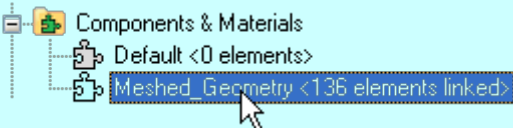

Right click the component and select **Assign new material**. In the **Mechanical** tab select **Isotropic** then type 200E09 in the text box for Young's modulus

Step 4

Right click **Surface5** and select **New loads and constraints**, then **Fixed Support**.

Drag with the middle mouse button to dynamically rotate the model's view for the next step.

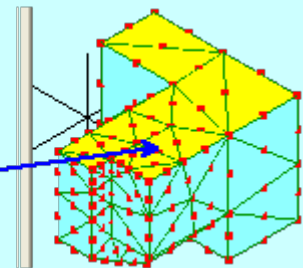
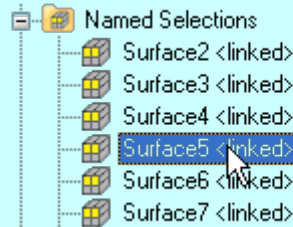

Step 5

Right click **Surface7** and select **New loads and constraints**, then select **Pressure**. Type **1000** to apply a normal pressure to the selected surface.

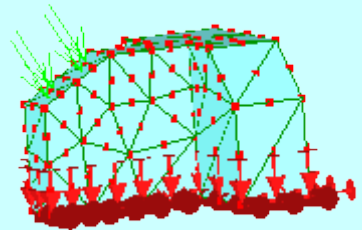

Step 6

Click **Solve**  then view the results

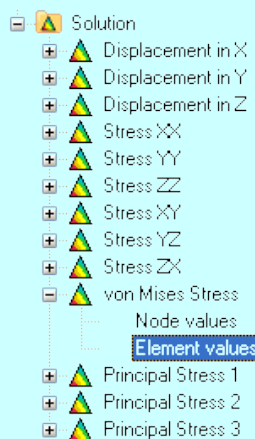

von Mises Stress

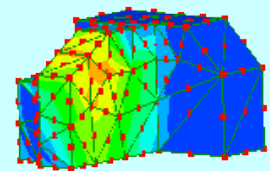
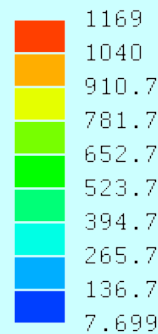

5.2 Automeshed CAD models default to millimeters

The automesher converts all CAD model dimensions to millimeters:

1. 1mm will remain 1mm
2. 1cm will become 10mm
3. 1m will become 1000mm
4. 1inch will become 25.4mm
5. 1foot will become 304.8mm

You have to use the **Mesh tools** → **Scale...** to restore it to the units of the CAD file.

5.2.1 Inch CAD tutorial

Step 1

Open **InchCadTutorial.stp** from the tutorials folder where LISA has been installed. The overall dimensions of this CAD model are 10"x10"x5".

Step 2

Right click the file name and select **Generate Mesh**

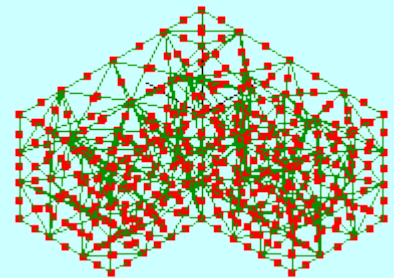
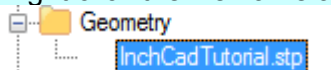

Step 3

Use the tape measure tool-button  to check the length of the automeshed part. Drag the mouse from one corner node to another.

The tape measure readout shows that the length is 254 and not the 10" length of the CAD model.

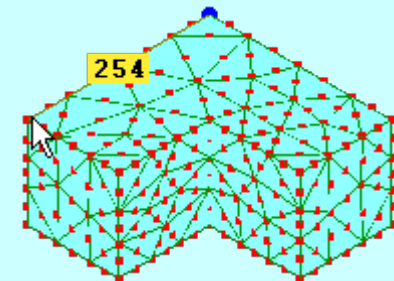

Step 4

The model will have to be re-sized by 0.03937 (1/25.4). **Mesh tools** → **Scale...**, type 0.03937 in the X, Y & Z text-boxes.

Use the tape measure tool to confirm that the edge length is now 10".

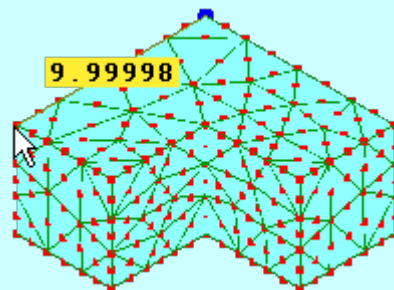

5.3 Local refinement tutorial

Step 1

Open **RefineLocal3dTutorial.stp** from the tutorials folder where LISA has been installed.

Step 2

Right click the filename and select **Generate mesh**

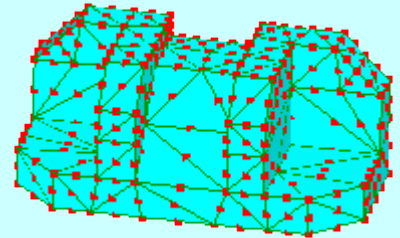
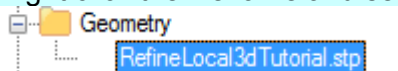

Step 3

We need the co-ordinates of the center of a sphere within which the refinement is to be applied.

Activate **Select nodes** 

Click a node and record the X, Y & Z co-ordinates.

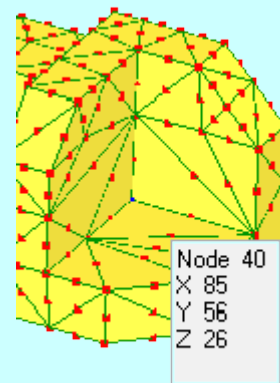

Step 4

Right click the filename and select **New local refinement**

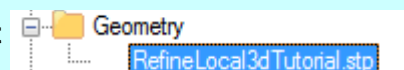

| | |
|-----------------------------|----|
| X | 85 |
| Y | 56 |
| Z | 26 |
| Radius | 20 |
| Maximum element size | 10 |

Step 5

Right click the filename and select **Generate mesh**

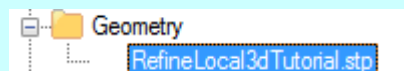

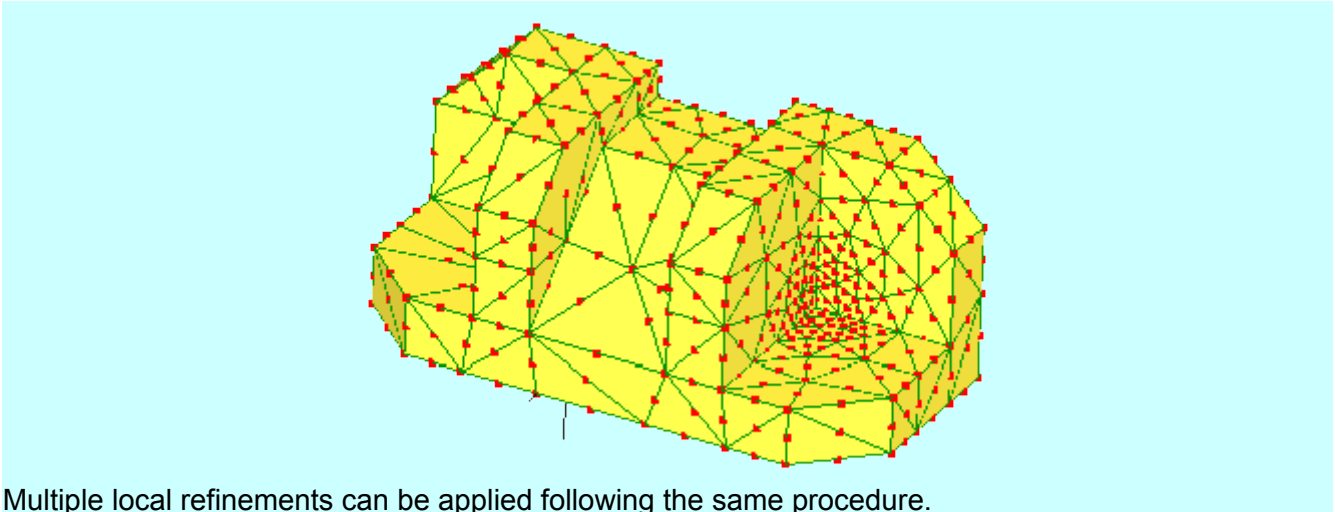

Multiple local refinements can be applied following the same procedure.

5.4 CAD assemblies

In order for the automeshing to operate, the assembly must be a single continuous CAD object. If you combine separate meshes the nodal patterns at the mating surfaces must match in order to be joined correctly into a continuous object. LISA does not have multi-point constraints to connect non-matching nodal patterns at assembly mating surfaces. Consider using beam elements with fictitious high stiffness properties to assemble parts.

Analysis Types

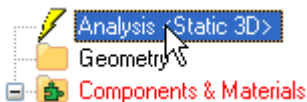

The analysis type determines what physical phenomena are modeled. LISA starts up with Static 3D as the default. Double click **Analysis** or right click it and select **Edit** to switch to another type of analysis such as thermal or modal vibration.

6.1 Static

Static analysis finds the steady state deformation and stress in a structure whose material has a linear stress-strain relationship.

6.1.1 Static 2D

Elements: Plane continuum (tri3, tri6, quad4, quad8, quad9), beam (line2), truss (line2), axial spring (line2)

Loads and constraints: Fixed Support, Displacement, Force, Pressure, Line Pressure, Moment, Gravity, Centrifugal Force, Temperature, Thermal Stress, rotz, nodetemperature, transformrz, mass, Coupled DOF

In Static 2D analysis, all nodes should lie in the XY plane because the Z coordinates are ignored by the solver. Each node has either 2 or 3 DOFs: Nodes of beams have displacement in X, displacement in Y and rotation about Z while nodes of plane, truss and axial spring elements have only the two displacement DOFs.

6.1.2 Static 3D

Elements: Solid continuum (tet4, tet10, pyr5, pyr13, wedge6, wedge15, hex8, hex20), shell (tri6, quad4, quad8, quad9), beam (line2), truss (line2), axial spring (line2)

Loads and constraints: Fixed Support, Displacement, Flexible Joint, Force, Pressure, Line Pressure, Moment, Gravity, Centrifugal Force, Temperature, Thermal Stress, Cyclic Symmetry, rotx, roty, rotz, nodetemperature, transformrx, transformry, transformrz, mass, Coupled DOF

In Static 3D analysis, solid, truss and axial spring elements have 3 DOFs each: displacement in X, Y and Z. Shells and beams have 6 DOFs each: 3 displacements and also rotation about X, Y and Z. You can combine all the different element types in the same model.

6.1.3 Static Axisymmetric

Elements: Axisymmetric continuum (tri3, tri6, quad4, quad8, quad9)

Loads and constraints: Fixed Support, Displacement, Force, Pressure, Line Pressure, Gravity, Centrifugal Force, Temperature, Thermal Stress, nodetemperature, transformrz, mass

Only plane elements can be used here and they will be treated as axisymmetric elements. The Y axis is the axis of symmetry and the X axis is the radial direction. Each node must lie in the two positive X quadrants of the XY plane and have zero Z coordinates.

All nodes have two DOFs: displacement in X and displacement in Y.

6.2 Modal Vibration

Free vibrations of a structure occur due to its own elastic properties when it is disturbed from its equilibrium state. These vibrations only occur at discrete natural frequencies. The two properties required for vibrational motion are:

- elasticity which returns the disturbed structure back to its equilibrium state, and
- inertia (from the mass) of the structure which makes it overshoot its equilibrium state.

Modal vibration analysis finds the natural frequencies of a structure and the corresponding deflected shapes (mode shapes). This is done without regard to how the vibration was initiated. All the nodes move with simple harmonic motion in phase with one another at the same frequency. Therefore all the time-dependent displacements reach their maximum magnitudes at the same instant of time.

The magnitudes of the displacements and nodal rotations given by LISA are only relative to the other displacements and rotations in the same mode shape. Their absolute magnitude has no meaning.

The maximum number of modes is equal to the number of unconstrained DOF in the model. For example, if a model is a single hex8 element with a fixed support applied to one face, the maximum number of modes will be 12, which is the number of DOFs per node (3) multiplied by the number of unconstrained nodes (4). Unless there is shock loading, only the modes of the lowest frequencies are important in the structural response. The **Default Iterative** matrix solver cannot find the highest one or two modes. If you want to find all the modes then use the **Direct** solver. However this is much slower for models with more than a few hundred nodes.

6.2.1 Modal Vibration 2D Plane and Truss

Elements: Plane continuum (tri3, tri6, quad4, quad8), truss (line2), axial spring (line2)

Loads and constraints: Fixed Support, Displacement, mass

With this analysis type, only two-dimensional truss elements, springs and membrane (plane continuum) elements in plane stress can be used. Membrane elements are appropriate for finding the in-plane vibration modes of a thin sheet while ignoring the out-of-plane modes. Truss and spring elements can be connected to the membrane elements or used on their own.

The model must be made in the XY plane. All Z-coordinates of nodes are ignored by the solver.

6.2.2 Modal Vibration 2D Beam

Elements: Beam (line2)

Loads and constraints: Fixed Support, Displacement, rotz, mass, rotationalinertiaz

Here only 2D beam elements can be used. The model must be made in the XY plane. All Z-coordinates of nodes are ignored by the solver.

6.2.3 Modal Vibration 3D Solid and Truss

Elements: Solid continuum (tet4, tet10, pyr5, pyr13, wedge6, wedge15, hex8, hex20), truss (line2), axial spring (line2)

Loads and constraints: Fixed Support, Displacement, Force, Pressure, Line Pressure, Gravity, Centrifugal Force, Temperature, Thermal Stress, Cyclic Symmetry, Stress Stiffening, nodetemperature, transformrx, transformry, transformrz, mass

This analysis type is the most generally useful. It can model arbitrary 3D geometries using solid elements as well a truss elements and springs.

The state of stress of a structure can influence its natural frequencies. This effect, called stress stiffening, is particularly apparent in a tensioned cable or guitar string. Static loads can also be applied to use with stress stiffening.

6.2.4 Modal Vibration 3D Shell and Beam

Elements: Shell (quad8), beam (line2)

Loads and constraints: Fixed Support, Displacement, rotx, roty, rotz, mass, rotationalinertiax, rotationalinertiay, rotationalinertiaz

This analysis type is useful for space frames and structures made from thin sheets. Every node has 3 rotational DOF as well as 3 translational DOF, one on each axis.

6.2.5 Modal Vibration 2D Transverse Vibration of Membrane

Elements: Plane continuum (tri3, tri6, quad4, quad8)

Loads and constraints: Fixed Support, Displacement, Tension Per Length

This is a special analysis type for modeling flat sheets of material with negligible bending and shear stiffness but which gain stiffness from their tension. An example is a drumhead. The tension must be uniform over the entire model and is applied using the Tension per length load.

The same structures can typically also be modeled in Modal Vibration 3D Solid and Truss using solid elements with stress stiffening. However that usually requires a finer mesh and it can be difficult to apply loads that lead to uniform tension.

6.3 Modal Response

Modal response has the same function as the dynamic response analysis types - it finds the time dependent deformation of a structure in response to time dependent loads. Modal response uses the mode superposition method which first finds the natural frequencies and mode shapes by solving an eigenvalue problem then generates nodal displacements and rotations at each time step. There are several other differences of modal response from dynamic response in LISA:

- Stresses are not produced.
- It is only suitable for small models, typically less than 1000 nodes, because it finds all modes using the direct matrix solver.
- It can be much faster when a large number of time steps are required.
- Beam elements are available but they cannot be mixed with any other element type.
- Quadratic solid elements (tet10, pyr13, wedge15, hex20) are available.

6.3.1 Modal Response 2D Plane and Truss

Elements: Plane continuum (tri3, tri6, quad4, quad8), truss (line2), axial spring (line2)

Loads and constraints: Fixed Support, Displacement, Force, Pressure, Line Pressure, mass

The model must be made in the XY plane. All Z-coordinates of nodes are ignored by the solver.

6.3.2 Modal Response 2D Beam

Elements: Beam (line2)

Loads and constraints: Fixed Support, Displacement, Force, Pressure, Line Pressure, Moment, rotz, mass, rotationalinertiaz

Here only 2D beam elements can be used. The model must be made in the XY plane. All Z-coordinates of nodes are ignored by the solver.

6.3.3 Modal Response 3D Solid and Truss

Elements: Solid continuum (tet4, tet10, pyr5, pyr13, wedge6, wedge15, hex8, hex20), truss (line2), axial spring (line2)

Loads and constraints: Fixed Support, Displacement, Force, Pressure, Line Pressure, mass

This analysis type can model arbitrary 3D geometries using solid elements as well a truss elements and springs.

6.3.4 Modal Response 3D Beam

Elements: Beam (line2)

Loads and constraints: Fixed Support, Displacement, Force, Pressure, Line Pressure, Moment, rotx, roty, rotz, mass, rotationalinertiax, rotationalinertiay, rotationalinertiaz

This analysis type is useful for space frames. Every node has 3 rotational DOF as well as 3 translational DOF, one on each axis.

6.4 Dynamic Response

When a part or structure is subjected to a time varying load, its stresses are amplified by an induced vibration. Dynamic response analysis takes this vibration into account when calculating the stresses & strains. It also calculates the velocities & accelerations in the model's response to the vibrating load.

LISA cannot model damping in dynamic response and initial conditions are zero displacement and velocity. You can impose an initial acceleration by applying a load at time zero.

The **Time step** affects the accuracy of the solution with smaller time step sizes being more accurate. You can choose a suitable time step size by first performing a modal vibration analysis to determine the period ($1/f$) of the highest mode of interest, then starting from that value, repeatedly reduce it and solve the problem again until the solution doesn't change significantly. When you reduce the time step you should also increase the **Number of time steps** by the same proportion to keep the total duration of the analysis unchanged. The total duration of the analysis should be at least the period of the lowest vibration mode. This ensures that all modes oscillate at least once.

Two solution algorithms are available, the **Newmark method** is suitable for most problems and it uses the constant average acceleration assumption which is unconditionally stable. The **Central difference method** typically requires much smaller time steps and may be unstable. The advantage of the central difference method is that each time step requires less CPU time to solve so it can be more efficient in some cases.

Decimation is available to reduce the number of time steps stored in the results. For example, if the model is solving for 1000 time steps you can enter 11 for the **Decimation number of time steps** and it will only output steps 0,100,200, ... , 1000 thereby using 1% of the memory that would be needed for storing all 1001 time steps.

6.4.1 Dynamic Response 2D

Elements: Plane continuum (tri3, tri6, quad4, quad8, quad9), truss (line2), axial spring (line2)

Loads and constraints: Fixed Support, Displacement, Force, Pressure, Line Pressure, Gravity, mass

6.4.2 Dynamic Response 3D

Elements: Solid continuum (tet4, hex8), truss (line2), axial spring (line2)

Loads and constraints: Fixed Support, Displacement, Force, Pressure, Line Pressure, Gravity, mass

Dynamic response tutorial

Step 1

Open **DynamicResponseTutorial.liml** from the tutorials folder where LISA has been installed.

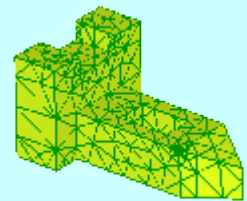

Step 2

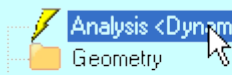

Right click **Analysis** and select **Edit**
→ **General** tab
Number of time steps 7
Time step 0.000415

Step 3



Activate the **Select nodes** mode and select this node.

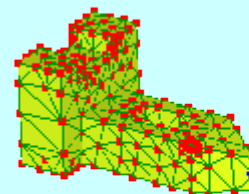

Node 117
X 0.258
Y -0.881
Z 0.084906

An applied force will ramp up linearly from 0 to a maximum 500 then down to 0. At each time step LISA will determine the force by interpolating between the specified values.



Right click **Loads & Constraints** and select **New force**
Named selection Create from current selection

X

| | | |
|--------------|----------|-----|
| Table | 0 | 0 |
| | 0.001535 | 500 |
| | 0.00307 | 0 |

Step 4

Named Selections
Surface15 <57 faces>

Right click Surface15 and select **New loads & constraints** → **New fixed support**

Step 5

Solve

Select any of the results below the Solution group in the outline tree.

Drag the slider on the timeline to display the results at the various time steps. Select a node to display a graph of its displacement.

6.4.3 Dynamic Response Axisymmetric

Elements: Axisymmetric continuum (tri3, tri6, quad4, quad8, quad9)

Loads and constraints: Fixed Support, Displacement, Force, Pressure, Line Pressure, Gravity, mass

6.5 Buckling

Linear eigenvalue buckling analysis, such as that provided with LISA, is only capable of describing bifurcation buckling with a constant, symmetric load-deflection relationship as shown below. An Euler column is used as an example, but the same curve can be applied to other structures. Here deflection is the displacement perpendicular to the direction of the load. Symmetric means the structure must be equally able to buckle in two opposite directions. There should also be negligible displacement in any direction prior to buckling.

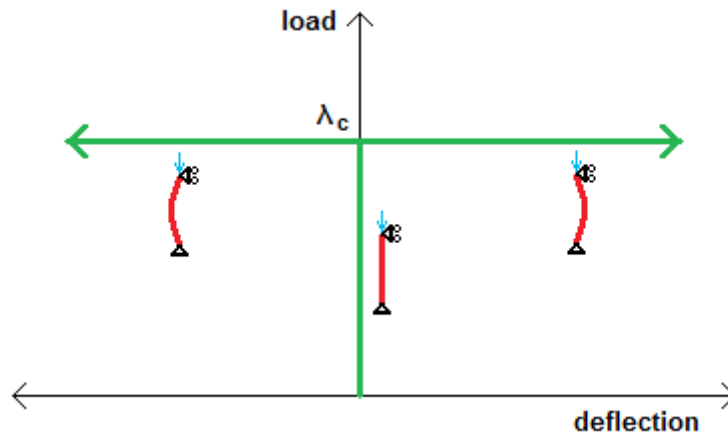

As the load is increased from 0 to the critical load λ_c , the structure remains in its original configuration with no deflection. When the load reaches λ_c , the deflection is indeterminate and increases with no further increase of the load.

Some real structures closely approximate this behaviour, while others are so different that eigenvalue buckling analysis is of no use. You should take care to ensure that these assumptions are appropriate to the problem otherwise the buckling factors may be grossly in error even if the mode shapes are reasonable.

An important class of problems for which eigenvalue buckling analysis is usually unsuitable is limit point instability. Here the structure continuously deflects by a finite amount as load is increased, until a 'limit point' of the load is reached, where it 'snaps through' into a different configuration. An example is a toggle mechanism.

These and other structures which appear to be buckling are in fact general non-linear problems. Another example is a column with an eccentric axial load. The deflection is non-zero for any finite load and there is no bifurcation point.

A thin-walled axially compressed cylinder appears to be a simple problem, but is very sensitive to initial imperfections. Experimental testing shows a wide scatter in critical loads. It also suffers from a range of other difficulties such as closely spaced buckling loads for many different modes, and the formation of plastic hinges on small initial buckles.

Spherical shells subject to uniform external pressure suffer some of the same difficulties as axially compressed cylinders. In both cases eigenvalue buckling analysis is likely to produce very misleading results.

Eigenvalue buckling analysis assumes no imperfections in the material or loading. For this reason the buckling factor is non-conservative and typically underestimates the actual buckling loads.

Each mode has an associated buckling factor. You can think of this as the safety factor. Instability occurs when all the loads are multiplied by the buckling factor. For thermal loads, instability occurs when each node's temperature is

$$T_{cr} = (T_{node} - T_{initial}) \times \text{buckling factor} + T_{initial}$$

and any mechanical loads are also scaled by the buckling factor. It can be convenient to specify unit loads in the model so that the buckling factor is equal to the critical load. If some loads are constant,

such as gravity, then you may need to perform several iterations to adjust the unknown loads until the buckling factor becomes 1.

The mode shape represents the relative movement of the nodes immediately after buckling occurs. The actual equilibrium shape of a structure after buckling cannot be found using linear eigenvalue buckling analysis.

To use buckling analysis in LISA you must specify the **Number of modes** and a **Shift point**. The shift point controls the stability of the eigenvalue solver. It must not be zero and should be between zero and the lowest buckling factor. The closer it is to the buckling factors, the greater their accuracy. However modes with buckling factors below the shift point will not be found.

6.5.1 Buckling 2D Beam

Elements: beam (line2)

Loads and constraints: Fixed Support, Displacement, Force, Pressure, Line Pressure, Moment, rotz, mass, rotationalinertiaz

6.5.2 Buckling 3D Solid and Truss

Elements: Solid continuum (tet4, tet10, pyr5, pyr13, wedge6, wedge15, hex8, hex20), truss (line2), axial spring (line2)

Loads and constraints: Fixed Support, Displacement, Force, Pressure, Line Pressure, Gravity, Centrifugal Force, Temperature, Thermal Stress, nodetemperature, transformrx, transformry, transformrz, mass

LISA can model global buckling of a truss structure due to elastic deformation of the individual elements. However it does not consider buckling of individual truss elements. You can calculate these loads from a static analysis using the tensile force values and the Euler column buckling formula.

6.6 Thermal

Thermal analysis uses a single temperature DOF for each node. The solver computes heat flux from the temperature field. All thermal analysis types are 3D. However, you can make a 2D model using shell elements of any thickness laid in a plane.

6.6.1 Thermal Steady State

Elements: Solid continuum (tet4, tet10, pyr5, pyr13, wedge6, wedge15, hex8, hex20), shell (tri3, tri6, quad4, quad8, quad9), fin (line2, line3)

Loads and constraints: Temperature, Heat Flow Rate, Internal Heat Generation, Convection, Radiation, Cyclic Symmetry, nodetemperature, Coupled DOF

This finds the equilibrium temperature distribution in a structure after any transients have dissipated.

6.6.2 Thermal Transient

Elements: Solid continuum (tet4, wedge6, hex8), shell (tri3, tri6, quad4, quad8, quad9), fin (line2, line3)

Loads and constraints: Temperature, Heat Flow Rate, Internal Heat Generation, Convection, Radiation, nodetemperature

Thermal Transient analysis produces a time history of the temperature field through a structure. You can specify time-dependent loads and temperature constraints as well as an initial temperature distribution. For nodes with no initial temperature specified, LISA applies a default value of zero which may be unrealistic if you are using absolute units such as kelvin.

Decimation is available to reduce the number of time steps stored in the results. For example, if the model is solving for 1000 time steps you can enter 11 for the **Decimation number of time steps** and it will only output steps 0,100,200, ... , 1000 thereby using 1% of the memory that would be needed for storing all 1001 time steps.

Transient thermal tutorial

Step 1

Open **TransientThermalTutorial.liml** from the tutorials folder where LISA has been installed.

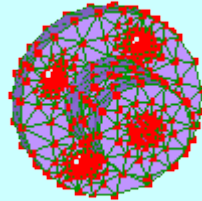

Step 2

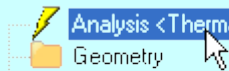

Right click **Analysis** and select **Edit General** tab

| | |
|-----------------------------|----|
| Number of time steps | 30 |
| Time step | 10 |

The duration of the analysis is $30 \times 10\text{s} = 300\text{s}$ or 5 minutes.

Step 3

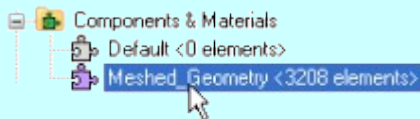

Right click **Meshed_Geometry** and select **Assign new material**

| | |
|---------------------------------------|--------|
| Mechanical tab | |
| Isotropic Density | 0.0027 |
| Thermal tab | |
| Isotropic Thermal conductivity | 0.204 |
| Specific heat | 890 |

Step 4

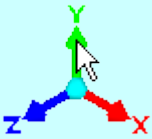

Right click the arrowhead of the Y-axis to display the model parallel to the screen.

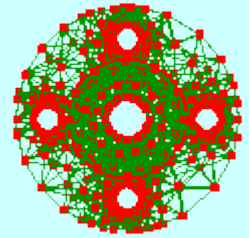

Activate the **Select nodes** mode.

Drag to select the entire mesh.

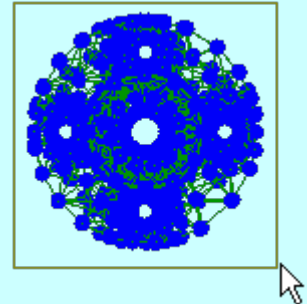

Edit → Circle selection

Hold the **Ctrl** key down and drag to deselect the nodes of the inner diameter.

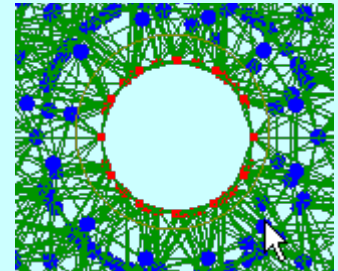

Initial Conditions

Right click **Initial Conditions** and select **New temperature**
Named selection Create from current selection
Constant 22

This sets the selected nodes to an initial temperature of 22. The reason the nodes of the inner diameter were deselected is because a constant temperature is going to be applied to the inner diameter. It's not physically possible for a node to be both at an initial temperature of 22 and a different constant temperature at the same time.

Step 5

We will now fix the temperature at the internal diameter to 120 for the entire analysis.

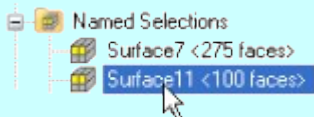

Right click **Surface11** and select **New loads & constraints**
→ **New temperature**
Named selection Surface 11
Apply at all times
Constant 120

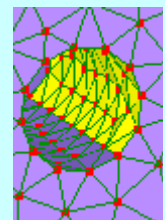

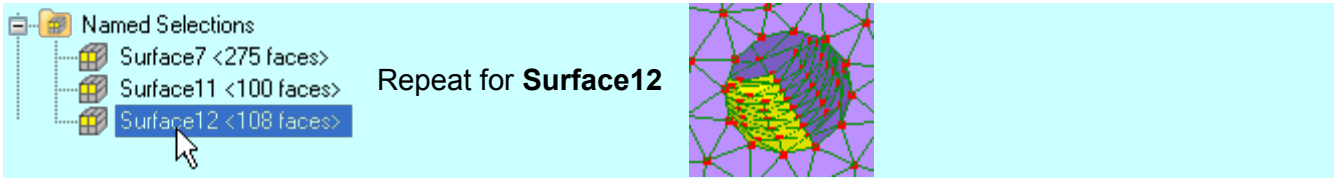

Step 6

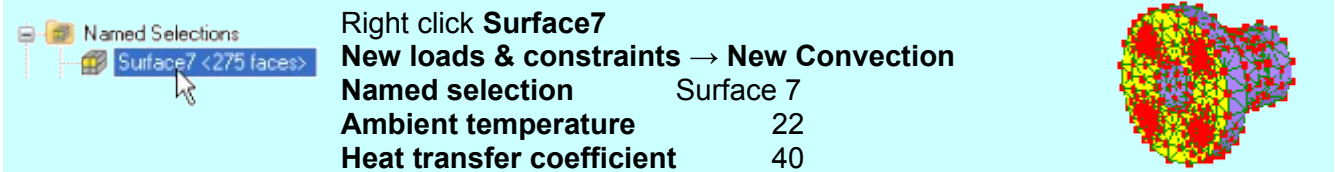

Step 7

Solve

Select any of the results listed below solution.

Drag the slider on the timeline to display the results at the various time steps. Select a node to display a graph of its temperature.

6.7 Fluid Potential Flow

Potential flow is an idealized fluid flow described by Laplace's equation $\nabla^2\phi = 0$ where ϕ is the velocity potential. The flow must be incompressible, irrotational and inviscid. Velocity potential is the single degree of freedom used in this analysis type. A gradient in the velocity potential field corresponds to a velocity in a way which is analogous to how a temperature gradient exists with heat flow or an electric potential gradient with current flow.

Three types of boundary condition are available. Where no boundary conditions are specified the default is zero velocity normal to the boundary, which can represent the walls of a container. You can also apply a known flow rate or velocity potential. Fixing the velocity potential on a surface causes the flow to be normal to that surface. At least one node should have a velocity potential defined to ensure stability of the solver.

LISA will calculate velocity and dynamic pressure fields using the following equations:

$$\text{velocity } \mathbf{u} = -\nabla\phi$$

$$\text{dynamic pressure} = \rho u^2/2$$

To obtain dynamic pressure results, you must specify the fluid's density in the material properties, otherwise density is not required.

6.7.1 Fluid Potential Flow 2D

Elements: Plane continuum (tri3, tri6, quad4, quad8)

Loads and constraints: Flow Rate, velocitypotential

6.7.2 Fluid Potential Flow 3D

Elements: Solid continuum (hex8)

Loads and constraints: Flow Rate, velocitypotential

6.8 Fluid Navier-Stokes Equations

Fluid Navier-Stokes Equations is used to find steady state solutions to the Navier-Stokes equations, which can represent rotational, viscous flow. They are implemented according to [1].

The corner nodes of each element have three degrees of freedom u, p, v :

u = nodal fluid velocity in x-direction

v = nodal fluid velocity in y-direction

p = nodal static pressure.

The midside nodes have only two degrees of freedom, u and v . This means that the velocities are interpolated with quadratic shape functions and pressures are interpolated linearly with the shape functions of tri3 and quad4.

Boundary conditions can be fixed velocities (vel_x, vel_y) or fixed pressures ($nodepressure$). The walls of a vessel should have both velocity components set to zero to prevent flow through the wall and enforce the no-slip condition. Outside faces with no specified boundary conditions are automatically subject to

$$\frac{\partial u}{\partial n} = 0 \quad \text{and} \quad \frac{\partial v}{\partial n} = 0$$

where $\frac{\partial}{\partial n}$ is the partial derivative with respect to the face normal. For example a face perpendicular

to the X axis with no other velocity constraints will have $\frac{\partial u}{\partial x} = 0$ and $\frac{\partial v}{\partial x} = 0$

The solver finishes when the relative change in nodal field values between subsequent iterations falls below the **Convergence tolerance**. Typically 0.01 is adequate.

The solution of each iteration is multiplied by the **Relaxation factor** then used as input to the next iteration. High values such as 1 lead to faster solving but can cause oscillation in some cases. If it fails to converge, reduce this closer to zero.

Approximate nodal velocities can be specified to begin the iteration. They are $startvel_x$ and $startvel_y$ and can be extracted from a previous solution using **Transfer start velocities from solution**. Usually this is unnecessary, but it can help guide unstable problems towards convergence. It can also speed up the solution process.

Many cases where the solver fails or doesn't converge can be caused by its inability to represent unsteady flow which may be caused by turbulence or vortex shedding. Sharp changes in boundary conditions or geometry can lead to such failures. Insufficient constraints on both velocity and pressure can also prevent a solution being found.

6.8.1 Fluid Navier-Stokes Equations 2D

Elements: Plane continuum (tri6, quad8)
 Loads and constraints: velx, vely, nodepressure, startvelx, startvely

6.8.2 Fluid Navier-Stokes Equations Axisymmetric

Elements: Plane continuum (tri6, quad8)
 Loads and constraints: velx, vely, nodepressure, startvelx, startvely

6.9 Fluid Non-Newtonian Conduit Cross-Section

Elements: Plane continuum (tri3, tri6, quad4, quad8)
 Loads and constraints: Pressure Gradient Z, velz

In this analysis type the 2D model represent the cross-section of a uniaxial pressure driven flow through an arbitrarily shaped conduit. The fluid can be an incompressible, non-Newtonian fluid represented by the Herschel-Bulkley model. Examples of such fluids are crude oils, slurries and suspensions.

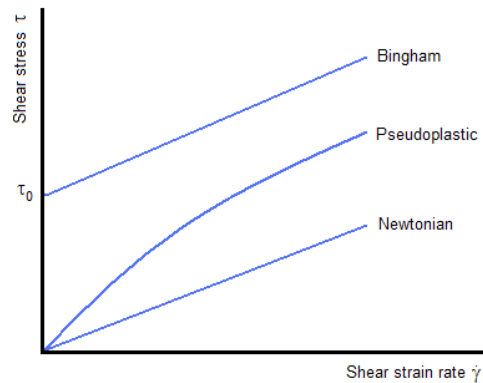
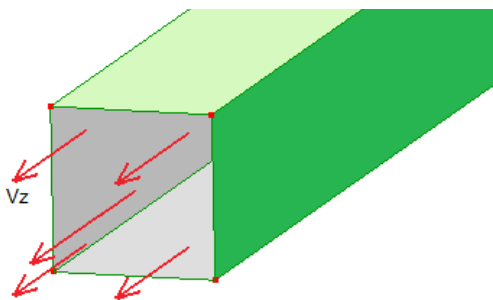

LISA calculates an effective viscosity $\tau/\dot{\gamma}$ according to the following formula

$$\tau = K \dot{\gamma}^n + \tau_0$$

K: consistency index

n: flow behaviour index

τ_0 : critical shear stress

For a Bingham fluid, $n=1$. For a pseudoplastic fluid, $\tau_0=0$. For a Newtonian fluid $n=1$, $\tau_0=0$, and K =dynamic viscosity.

You should apply a Pressure Gradient Z load to all elements participating in the pressure driven flow. Boundary conditions can be applied at nodes to give a no-slip condition ($vel_z=0$), zero shear (default) or fixed velocity in Z ($vel_z \neq 0$).

6.10 DC Current Flow

Elements: Solid continuum (tet4, tet10, pyr5, pyr13, wedge6, wedge15, hex8, hex20), shell (tri3, tri6, quad4, quad8, quad9), resistor (line2)

Loads and constraints: Voltage, Current, Robin Boundary Condition, Coupled DOF

This analysis type finds the electric potential (voltage relative to an arbitrary zero) distribution throughout a structure. This electric potential which is the single DOF at each node, is then used to obtain current density, resistive power loss (ohmic heating) and current in resistor elements.

6.11 Electrostatic

Electrostatic analysis models static electric fields in insulating dielectric material.

You can specify the **Permittivity of free space** ($8.854187818 \times 10^{-12}$ F/m) for the model and relative permittivities on materials.

Each node's DOF is electric potential (voltage relative to an arbitrary zero) so electric potential should be constrained at at least one node to ensure a unique solution. The solver then uses the electric potential field value to obtain the electric field and flux density.

6.11.1 Electrostatic 2D

Elements: Plane continuum (tri3, quad4)

Loads and constraints: Voltage, Charge, Robin Boundary Condition, Coupled DOF

6.11.2 Electrostatic 3D

Elements: Solid continuum (tet4, tet10, pyr5, pyr13, wedge6, wedge15, hex8, hex20)

Loads and constraints: Voltage, Charge, Robin Boundary Condition, Coupled DOF

6.12 Magnetostatic 2D

Elements: Plane continuum (tri3, quad4)

Loads and constraints: Current, Magnetic Vector Potential, Robin Boundary Condition, Coupled DOF

Magnetostatic analysis models a static magnetic field caused by conductors carrying current perpendicular to the plane of the model.

You can specify the **Permeability of free space** ($1.256637061 \times 10^{-6}$ H/m) for the model and relative permeabilities on materials.

Each node has a single DOF which is the Z component of the magnetic vector potential. From this field value the solver generates a description of the magnetic field as B and H vector fields.

6.13 Acoustic Cavity Modes

This analysis type can find vibration modes of fluid in an enclosed cavity such as sound resonance in a room or vehicle cabin. It cannot model openings in the walls of the cavity such as windows or doors. If you need to model an opening in an object, you need to embed the object in a larger 'room' which itself is fully closed. However, you will then need to distinguish the acoustic behavior of the object from that of the enclosing room.

The modes are solutions to the Helmholtz equation

$$\nabla^2 p + (\omega/c)^2 p = 0$$

where p is the pressure relative to ambient, ω is the angular frequency of the mode, and c the speed of sound in the medium.

Continuum elements represent the medium inside the cavity. Boundary faces without any constraints behave like hard surfaces with the following Neumann boundary condition

$$\nabla p \cdot \underline{n} = 0$$

where \underline{n} is the surface normal vector. This means some of the pressure anti-nodes will occur at the boundaries.

The mode shapes (pressure) shown in the solution are the instantaneous pressure of the standing waves which will oscillate sinusoidally with time. Their amplitudes are arbitrary. The mode frequencies shown in the solution are the angular frequencies ω .

6.13.1 Acoustic Cavity Modes 2D

Elements: Plane continuum (tri3, tri6, quad4, quad8)

Loads and constraints: nodepressure

6.13.2 Acoustic Cavity Modes 3D

Elements: Solid continuum (tet4, wedge6, hex8)

Loads and constraints: nodepressure

Elements

7.1 Plane Continuum Elements

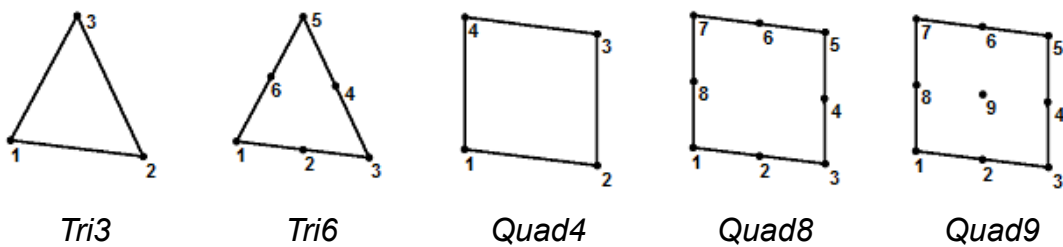

Plane elements can be used for various 2D analysis types to represent structures such as flat plates or prismatic rods. Their nodes should lie in the XY plane.

The quadratic elements (those with midside nodes) can have parabolically curved sides although they are displayed as being straight. You can see the curved shape by refining the element as shown below.

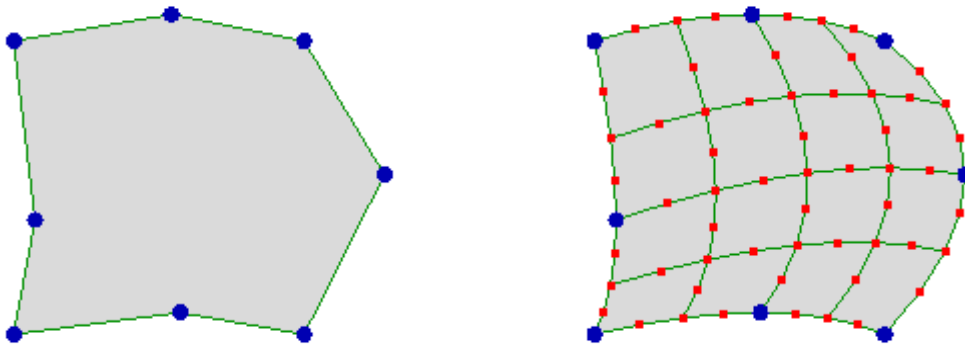

Quadratic elements typically perform better than the linear elements because the DOF field value can vary quadratically along their edges whereas the linear elements only allow a linear variation. In mechanical analysis types the linear elements, especially tri3 (constant strain triangle), have a further limitation of being too stiff in bending. To model bending accurately with linear elements you must refine the mesh so that each individual element experiences mostly tension or compression and less bending.

7.2 Axisymmetric Continuum Elements

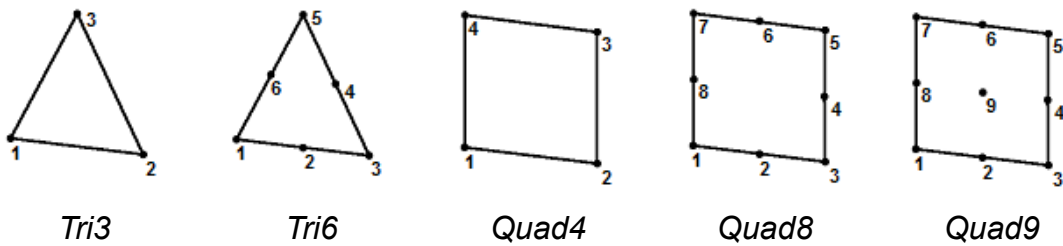

Although these appear to be the same as plane continuum elements, each axisymmetric element actually represents an entire circular solid as shown below. The axis of symmetry is the Y-axis and elements must be located in the X-Y plane with all X-coordinates non-negative. Axisymmetric elements can only be used in the axisymmetric analysis types.

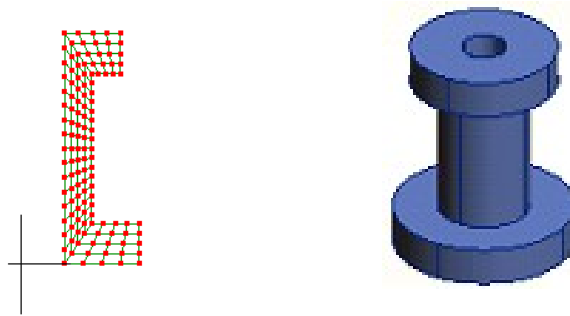

In mechanical analysis types, each node has 2 DOFs: displacement in X(radial) and displacement in Y(axial). Any nodes located at X=0 must be restrained to not be displaced in the X direction because it is physically unreasonable that the material should overlap itself or for a hole to appear. Also, rigid body motion can only occur by translation along the Y-axis, so only translational motion in the Y direction needs to be constrained to prevent rigid body motion.

7.3 Solid Continuum Elements

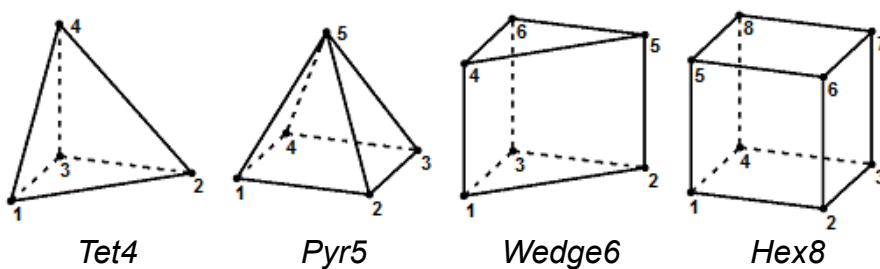

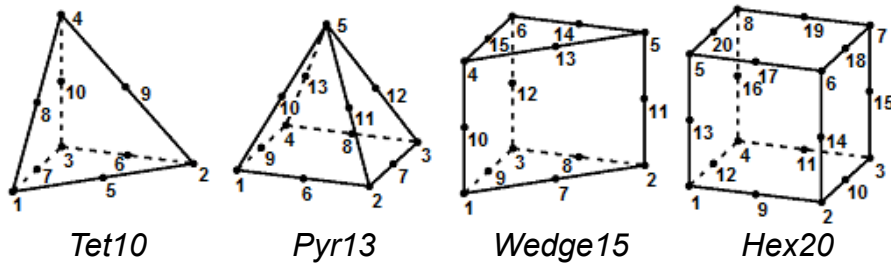

Solid elements are the most general and, in principle, can be used to model any shaped structure. However some geometries such as thin beams or plates can require a such a large number of solid elements that the solver runs out of memory or takes too much time. In these cases you can further idealize the model by using shells, beams, fins, resistors, etc. instead of solid elements.

In mechanical analysis types, hex20 typically performs much better than all the other solid elements. This means you attain the same accuracy with fewer elements.

7.4 Shell

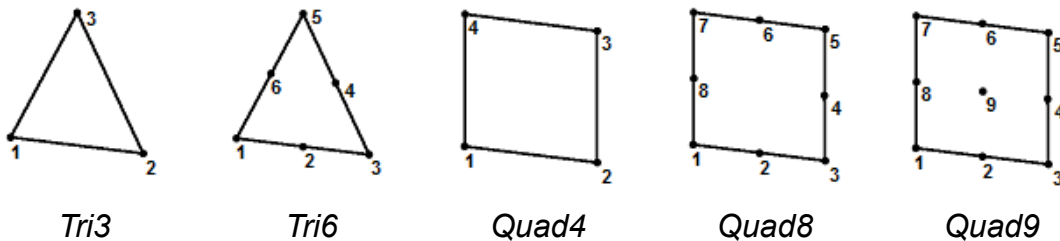

Shells are 3D elements that can model stress, heat flow or electric current in the plane of the element but not through the thickness. They are useful for thin parts where solid elements are too computationally expensive or in place of 2D elements where those are not available. Typical structures modeled with shell elements include sheet metal brackets and cabinets, thin metal platforms, pressure vessels, and body parts of motor vehicles.

In the mechanical analysis types, the elements use Mindlin thick plate theory which models out-of-plane bending and shear stiffness. They also incorporate plane stress membrane stiffness for in-plane deformation in the same way as the 2D membrane elements. Each node has 6 DOFs – displacement in X, Y and Z and rotation about X, Y and Z. However there is no drilling DOF which means each node is free to rotate about the shell's normal and is only resisted by an arbitrary small stiffness to ensure numerical stability. The tri3 shape is not available for static analysis and only quad8 is available in modal vibration.

The rotational DOFs of shells mean that you can join two shell elements together at a common edge and they will transmit bending moments between each other. This is distinct from solid elements which cannot transmit bending moments when they're only connected by an edge. If the straight edge of a shell is joined to the edge of a solid element, then it will form a hinge joint. To make a stiff joint, overlap the two elements.

In modal vibration, shells use consistent mass matrices with no rotational inertia at the nodes. This simplification typically doesn't cause problems because the effect of nodal rotational inertia vanishes with mesh refinement.

Each element has a local right-handed coordinate system U,V,W which is used for orienting orthotropic and laminate materials and for displaying some stress results. The W axis is normal to the element's surface. By default U is parallel to the edge from nodes 1 to 2, or 1 to 3 for linear or quadratic elements respectively. You can define the direction of the U axis by specifying a vector in global X,Y,Z coordinates. The direction of the U axis is the projection of this vector onto the plane normal to W. The V axis is mutually perpendicular to U and W.

Shell elements can be curved out of their plane but should be approximately flat because they are internally projected onto a 2D plane by the solver. Because of this, warped or doubly curved elements in mechanical analysis types can have slow convergence or may fail to converge at all with mesh refinement as shown in the sample TwistedBeam.liml.

The best accuracy and fastest convergence is typically obtained with the quad8 or quad9 shells. LISA uses various integration schemes for the different physical phenomena in each element shape as shown in the following table.

| Number of integration points | tri3 | tri6 | quad4 | quad8 | quad9 |
|------------------------------|------|------|-------|-------|-------|
| membrane | N/A | 7 | 4 | 9 | 9 |
| bending | N/A | 7 | 4 | 9 | 9 |
| shear | N/A | 7 | 1 | 4 | 9 |
| thermal | 1 | 7 | 4 | 9 | 9 |
| DC current | 1 | 7 | 4 | 9 | 9 |

Stress results for shells in static analysis are obtained from bending moments and membrane forces. Out-of-plane shear forces are disregarded. Stresses are not reported for laminate materials or modal vibration.

LISA reports **von Mises Stress** and the two in-plane **Principal Stresses** at three locations: the upper surface of the element, the midplane and the bottom surface of the element. The upper surface is the surface with a more positive W coordinate. The display shows all three results simultaneously when **Show thickness** is turned on, and shows only the upper and bottom stresses otherwise.

Stress UU, **Stress VV** and **Stress UV** are the membrane (midplane) stress components in the local element coordinate system. Because the shell has thickness, in bending, its stress will be different away from the midplane.

Moment U, **Moment V** and **Moment UV** are moments per unit length for out-of-plane bending and twisting. They are with respect to the local coordinate system of the element. Moment U is bending about the local V axis, and Moment V about the local U axis. Moment UV is the twisting (torsion) moment per unit length.

Shear UW and **Shear VW** are out-of-plane shear force per unit length. Divide by thickness to obtain the average shear stress components. Actual shear stress varies through the thickness.

7.5 Beam

LISA's beam elements use Euler beam theory which means they can model bending of slender, uniform, isotropic beams. They also have longitudinal and torsional stiffness allowing them to act as

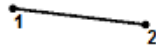

Line2

columns or shafts. Each node has both displacement and rotational DOFs so they can transmit bending and twisting moments between elements.

You can apply loads and constraints to the end faces or the side face.

An arbitrary cross sectional shape (**General section**) can be defined by its geometric properties, or various predefined shapes can be used depending on the analysis type:

| | |
|--------------------------------------------------------|--------------------------------------------------------------------------------------------------------|
| static 3D modal vibration 3D modal response 3D | I rectangular bar rectangular tube circular bar circular tube general section |
| static 2D | C T I rectangular bar rectangular tube circular bar circular tube general section |
| modal vibration 2D modal response 2D buckling 2D | general section |

The orientation of the beam cannot be fully defined by the locations of the nodes alone so there are other options to control how the cross section is rotated about the beam's longitudinal axis. These are available under **Element properties**.

In 3D, the element's local coordinate system, U, V, W defines the orientation of the cross-section.

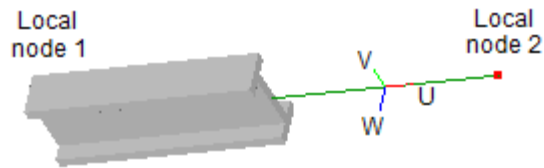

The U axis is parallel to the element's length, the V axis is perpendicular to U and the W axis is mutually perpendicular to both U and V according to $W=U \times V$. These constraints leave the V axis free to rotate about the element's longitudinal axis. There are two options for defining the direction of the V axis:

- **Default.** The V axis is perpendicular to the global Z axis and parallel to the XY plane. If the element is nearly parallel to the Z axis (gradient < 0.01%) then the V axis is made parallel to the Y axis too.
- **Direction of element V axis.** The V axis can be defined by a vector in the global X, Y, Z coordinate system. The specified vector might not meet the requirement of being perpendicular to U, so the V axis is the projection of this vector onto a plane perpendicular to U. This allows almost any vector to be used as long as it is not zero (0, 0, 0) and not be parallel to U. The magnitude of the vector is not used by LISA.

After defining the vector you can also apply a further rotation of V about U by a specified angle (**Rotate by angle**). This feature is useful if you know the angle in which you want to orient the beam but don't want to manually convert it to vector form. It can also be helpful if you want to specify a common direction of W for many elements in different orientations. You can set the vector to the direction of W then rotate it by -90° .

In 2D, the U, V, W element coordinate system is fully defined by the locations of the element's nodes, with W parallel to the global Z axis and in the same direction. However the orientation of the cross-section can be flipped so that it is still symmetric about the XY plane. Choosing the **2nd orientation** option will rotate I, rectangular bar and rectangular tube sections by 90° and C and T sections by 180° .

Beam stresses and forces are reported in static analysis only. Tensile stresses are the stresses at each of 4 predefined points in the cross-section and one user-defined **Stress recovery point in principal coordinates**. These stress values are calculated only from the normal force and bending moments. They do not incorporate shear stress caused by torsion or shear forces.

The results in static analysis show the forces and stresses at each end of each element. However the values at nodes are the averages of the elements connected to those nodes so these will often be misleading. You can display non-averaged values in the contour plot by selecting **Element Values** from under the relevant force or stress branches in the outline tree. You can also click on a node in the graphics area to show the values at all its adjacent elements.

7.6 Truss

A truss element is a beam hinged at both ends so that it can only resist axial compressive or tensile forces and has no bending or torsional stiffness. Each node has translational degrees of freedom in the the X, Y and, if 3D, Z directions.

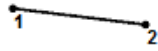

Line2

Truss elements can be used to model truss structures where no bending occurs in individual members, as well as to transmit forces between objects and create hinge joints between beam or shell elements.

To convert a beam element into a truss element, select the desired elements, right click on one of them, click **Element properties** and check **Truss**.

Only static 3D models can use all the uniform section shapes (C, T, L, I, rectangular bar, rectangular tube, circular bar, circular tube and general section) for trusses. Static 2D disallows L section, and in other analysis types only the general section can be used. No orientation needs to be specified like for beam elements.

The results in static and dynamic response show the axial force and stress at each end of each element. However the values at nodes are the averages of the elements connected to those nodes so these will often be misleading. You can display non-averaged values in the contour plot by selecting **Element Values** from under the **Tensile Force** or **Tensile Stress at User Defined Point** branches in the outline tree. You can also click on a node in the graphics area to show the values at all its adjacent elements.

7.7 Axial Spring

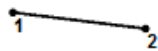

Line2

The axial spring element has stiffness only in the direction of its length and is hinged at its endpoints. It can be used anywhere that a truss element can. Each node has 2 or 3 translational degrees of freedom along the X, Y and Z axes depending on the number of dimensions (2D or 3D).

You can define an axial by applying the **Spring** mechanical material type to a line2 element. You can also specify the spring constant and free length.

The **Spring constant** k is the stiffness in Hooke's law

$$F = -k u$$

where F is the extending force exerted by the spring and u is the increase in length from the free length.

Free length is useful in static and buckling analysis only. It allows the spring to be preloaded to the element's modeled length and it will produce its own restoring force when solved. If you don't specify a value for free length then it defaults to the element's modeled length.

A spring element behaves identically to a truss element with zero density. The equivalent truss element satisfies the equation

$$\text{cross-sectional area} \times \text{Young's modulus} = \text{spring constant} \times \text{length}$$

7.8 Fin



Line2

Line3

The rate of heat removed by convection from a surface is increased by increasing the surface area for heat transfer using extended surfaces called fins. A simple example is a metal spoon placed in a glass of hot water, heat is conducted through the spoon to cause the handle to become warmer than the surrounding air. Heat is then transferred from the spoon handle to the air by convection. Similarly, industrial applications use fins in car radiators, double pipe heat exchangers, electronic equipment and compressors.

A fin element models heat conduction along its length but not across its width. It can also have convection and radiation heat transfer applied to its side face and/or end faces.

7.9 Resistor

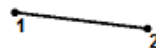

Line2

A resistor element has a linear change in potential over its length according to Ohm's law $V=IR$. It's resistance can be defined by either using the single extensive property resistance, or by its material's conductivity together with the geometry of a beam. Any of the uniform section shapes (C, T, L, I, rectangular bar, rectangular tube, circular bar, circular tube, general section) can be used.

Resistors can be useful for modeling linear electric circuits as well as for measuring current values in 3D continuum or shell models. To find the current flowing through a complex object, you can place a resistor element with near-zero resistance in series with the object. The solution will then show the current flowing in the resistor.

Materials

Elements are designed to mathematically represent various types of materials for both their physical properties and their geometric shapes.

8.1 Materials database

LISA does not provide a materials database. If you find yourself using the same materials repeatedly, create an empty LISA file with only the materials defined in it, then when you need a material, open it using **Load into model** from the **File** menu. This will import those materials into the currently open model.

8.2 Defining a new material

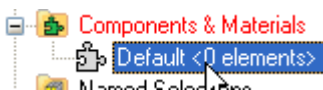

Right click a component in the outline tree to **Assign new material**

8.3 Mixed materials

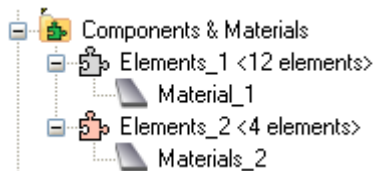

In order to have a more than one different material in a model, the elements with different materials need to be in different components.

The 3D automeshing can't make parts with defined boundaries between different material types. To get a perfect boundary between different materials, mesh it manually or use the automeshing for the more complex part then manually build the simpler part onto it.

8.3.1 Mixed material tutorial

Step 1

Open a new instance of LISA.

Step 2

Click **Quick cube** 

Step 3

Click **Refine** 

Step 4

Right click the **Default** component in the outline tree and select **Assign new material**. Choose **Isotropic** and enter:

Young's modulus 200e9

Poisson's ratio 0.3

Click **Close**

Step 5

Change to **Select elements** mode  and select two of the 8 elements. Hold the **Ctrl** key while clicking on each element.

Step 6

Right click one of the selected elements and choose **Add elements to new component**. The newly created Material(2) is a duplicate of the first material but you can change its properties independently.

Step 7

Click on an empty space in the graphics area to clear the selection then click **Show element surfaces** . Notice that each material's component has a different color so you can easily distinguish them.

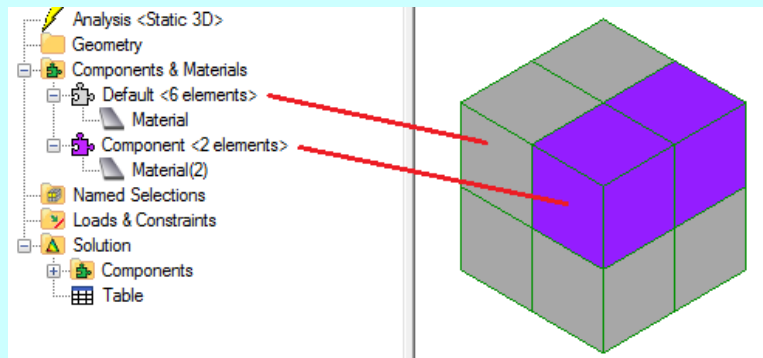
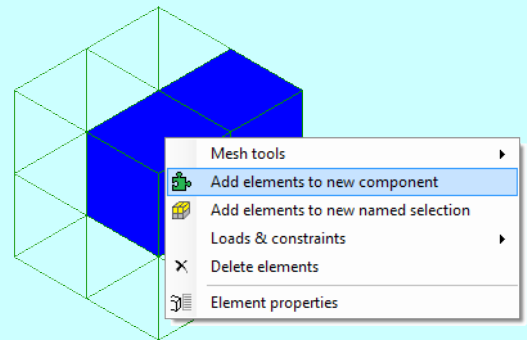
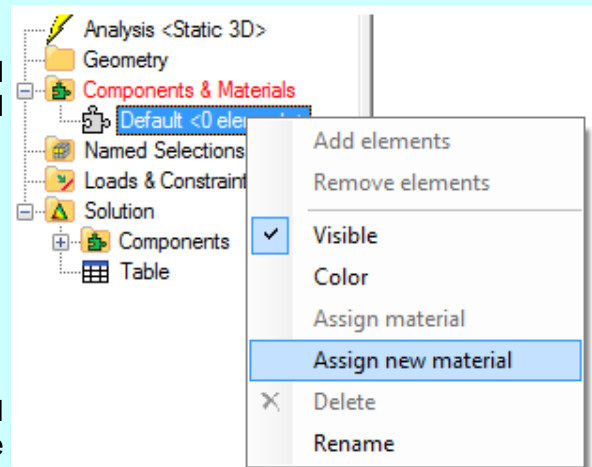

8.4 Mixed elements

Element types can be mixed in the same model, but each should have its own material definition because their geometrical properties are not the same.

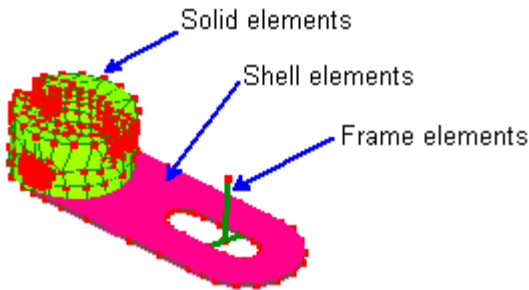

8.5 Orthotropic & anisotropic materials

Orthotropic materials have mechanical properties that differ along directions which are perpendicular with each other. In LISA, orthotropic materials can be specified for 3D solid, 2D membrane and shell elements. For solid elements, the properties will differ along the global X, Y, Z-axis directions. For 2D membrane elements, the properties will differ along the global X & Y-axis directions. For shells, the properties will differ along their local U, V co-ordinate axes rather than the global X, Y, Z-axes. The local axes of shells can be displayed using this tool-button .

Anisotropic materials have mechanical properties that differ along arbitrary directions which are not perpendicular with each other.

In LISA, Young's modulus can be defined separately for each direction of orthotropic materials and for anisotropic materials the coefficients of the elasticity matrix are specified.

8.6 Temperature dependent properties

You can specify temperature dependent thermal conductivities and specific heat values. The solver linearly interpolates between the specified data points. If a temperature is outside of the range, the solver uses the nearest data point rather than attempting to extrapolate.

Loads and Constraints

9.1 Fixed Support

Analysis types: Static, Modal Vibration, Modal Response, Dynamic Response, Buckling

A fixed support constrains all the face's nodes against displacement in any direction. If any nodes have rotational degrees of freedom then those are also constrained against rotation.

A fixed support can only be applied to a named selection containing faces.

9.2 Displacement

Analysis types: Static, Modal Vibration, Modal Response, Dynamic Response, Buckling

A displacement constraint enforces the specified displacement on every node in the named selection it is applied to. The displacement is only constrained in the specified direction and the nodes are free to move in perpendicular directions.

A displacement can be applied to a named selection containing nodes, faces or elements.

To constrain displacement in an arbitrary direction other than of one of the global X, Y or Z axes, you can rotate the nodes' coordinate systems by applying transformrx, transformry and/or transformrz to the nodes. This is useful for sliding supports on inclined surfaces.

In modal vibration, modal response, dynamic response and buckling the displacement must be zero.

9.3 Flexible Joint

Analysis types: Static 3D

A flexible joint releases the rotational stiffness of the end of a beam element allowing it to rotate freely even when it's connected to another element or has constrained rotation.

A flexible joint must be applied to named selections containing only end faces of beam elements.

The joint can allow rotation about any combination of the three local axes (U,V,W) of the beam element. The meaning of some combinations are:

- U – The element can rotate about its own axis like being connected to a roller bearing.
- V or W – A pin joint which allows the element to pivot about one axis.

- V and W – A universal joint which transmits torque but not bending moments.
- U,V and W – A ball joint which allows the element to rotate in any direction.

9.4 Force

Analysis types: Static, Modal Vibration 3D Solid and Truss, Modal Response, Dynamic Response, Buckling

A force applied to faces is distributed over the faces as a uniform traction with the same direction at every point and with a total magnitude equal to the magnitude specified. A force applied to nodes is divided equally between the nodes.

A force can be applied to a named selection containing nodes or faces. It can be constant or time dependent.

The force vector must be specified in global X, Y, Z coordinates.

9.5 Pressure

Analysis types: Static, Modal Vibration 3D Solid and Truss, Modal Response, Dynamic Response, Buckling

Pressure applies a force proportional to the area of the face. The direction of the force can be either normal to the face or specified in global X, Y, Z coordinates. For a normal pressure, a positive value directs the force in the opposite direction to the face normal, which is inwards for volume elements.

A pressure can only be applied to a named selection containing faces. It can be constant or time dependent. It can be used with most types of element used in the mechanical analysis types: plane continuum, solid continuum, axisymmetric continuum, shell, beam and truss but not axial spring elements because they have no surface area.

9.6 Line Pressure

Analysis types: Static, Modal Vibration 3D Solid and Truss, Modal Response, Dynamic Response, Buckling

Line pressure applies a uniform force per unit length to each face in the selection. The direction of the force can be specified in either global X, Y, Z coordinates or element U, V, W coordinates when applied to the edge faces of beam or truss elements.

A line pressure can only be applied to a named selection containing faces that are locally 1-dimensional. This includes the edges of plane and line elements such as shells and beams. It can be constant or time dependent.

9.7 Moment

Analysis types: Static 2D, Static 3D, Modal Response 2D Beam, Modal Response 3D Beam, Buckling 2D Beam

Moment applies a moment to the specified node. The direction of the moment vector is specified in global X, Y, Z coordinates. The moment is directed around this vector according to the right-hand grip rule.

A moment can only be applied to a named selection containing a single node which has rotational degrees of freedom. That is, the node should be part of a beam or shell element. It can be constant or time dependent.

9.8 Gravity

Analysis types: Static, Modal Vibration 3D Solid and Truss, Dynamic Response, Buckling

Gravity gives a distributed force to all massive parts of a model. This includes elements whose material has density and nodes with point mass loads applied to them. Specify a vector which is the force per unit mass. For Earth gravity in SI units you can use Y=-9.81.

9.9 Centrifugal Force

Analysis types: Static, Modal Vibration 3D Solid and Truss, Buckling

Centrifugal Force simulates rotation of the entire model and its global coordinate system. This gives every massive part (node or element) an outward force whose magnitude is

$$F = m \omega^2 r$$

where m is the part's mass, ω is the angular velocity and r is the distance from the axis of rotation. The axis of rotation must be one of X, Y or Z. To convert rotational speed in RPM to radians/s for angular velocity, multiply by $2\pi/60$.

9.10 Tension Per Length

Analysis types: Modal Vibration 2D Transverse Vibration of Membrane

This load applies a uniform 2D isotropic stress over all the elements in the model.

9.11 Temperature

Analysis types: Static, Modal Vibration 3D Solid and Truss, Buckling, Thermal

In a thermal analysis a temperature load constrains the temperature to the specified value at the items in the named selection. Heat is allowed to flow into or out of the model at these locations to maintain the specified temperature.

In a static or buckling analysis the temperature is used for thermal stress where a thermal stress load must also be applied.

Temperature can be applied to a named selection containing nodes, faces or elements.

The temperature can be constrained within a specified time interval in a thermal transient analysis. Within this interval, a constant or time-dependent temperature can be specified. In steady state analysis, temperature must be specified as a single constant without any time interval.

9.12 Thermal Stress

Analysis types: Static, Modal Vibration 3D Solid and Truss, Buckling

When present, thermal stress enables thermal loading. A single reference temperature must be specified as well as temperatures on parts of the model and thermal expansion coefficients in the materials.

The difference between each element's average specified temperature and the reference temperature is used to determine the thermal expansion/contraction loads. Any nodes that don't have a specified temperature are assumed to be at the reference temperature.

Only one thermal stress can be applied in a model.

9.12.1 Thermal stress tutorial

Step 1

Open **ThermalStressTutorial.liml** from the tutorials folder where LISA has been installed.

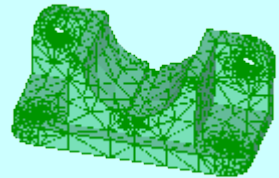

 Analysis <Thermal Steady State>

We will perform a thermal analysis first.

Step 2

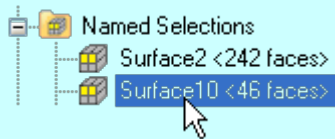

Right click **Surface10** and select **New loads & constraints** → **New temperature**

| | |
|------------------------|------------|
| Named selection | Surface 10 |
| Constant | 80 |

Repeat for **Surface 14**

Step 3

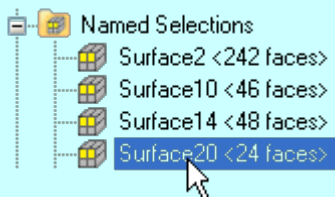

Right click **Surface20** and select **New loads & constraints** → **New convection**

| | |
|----------------------------------|------------|
| Named selection | Surface 20 |
| Ambient temperature | 22 |
| Heat transfer coefficient | 400 |

Repeat for **Surface 21** and **Surface 22**

Step 4

 **Solve**

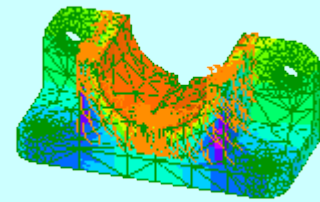

Step 5



Right click **Analysis** and select **Edit Analysis Type** tab
3D
Static 3D

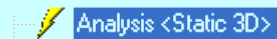

Step 6



Right click **Loads & constraints** and select **Transfer temperatures from solution**

Step 7

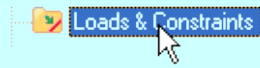

Right click **Loads & constraints** and select **New thermal stress Reference temperature 22**

The reference temperature is the initial temperature of the nodes that are now at the temperatures which were transferred from the thermal analysis solution.

Step 8



Right click **Material** and select **Edit Mechanical** tab
Isotropic
Young's modulus 200E09
Density 7800
Thermal expansion coefficient 11E-06

Step 9

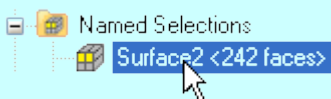

Right click **Surface2** and select **New loads & constraints** → **New fixed support**

Step 10

 **Solve**

9.13 Pressure Gradient Z

Analysis types: Fluid Non-Newtonian Conduit Cross-Section

This load specifies the Z component of the pressure gradient through the elements in a named selection. This pressure gradient can drive the fluid's flow in the Z direction.

9.14 Heat Flow Rate

Analysis types: Thermal

Heat is added to the model at the specified rate. It is distributed uniformly across the volume or surfaces it is applied to. If it is applied to nodes then the specified heat flow rate is divided equally between each node.

Heat Flow Rate can be applied to a named selection containing nodes, faces or elements.

A time-dependent Heat Flow Rate can be specified as a table of time and value pairs.

9.15 Internal Heat Generation

Analysis types: Thermal

Heat is added to the model at a uniform rate over the volume it applies to. The value specifies the rate at which heat is added to the model per unit volume.

Internal Heat Generation can be applied to a named selection containing elements.

A time-dependent Internal Heat Generation can be specified as a table of time and value pairs.

9.16 Flow Rate

Analysis types: Fluid Potential Flow

Fluid enters the model at the specified volumetric flow rate uniformly across the volume or surface it is applied to. If it is applied to nodes then the specified flow rate is divided equally between each node.

Flow Rate can be applied to a named selection containing nodes, faces or elements.

9.17 Voltage

Analysis types: DC Current Flow, Electrostatic

Voltage applies a uniform voltage over every item in the named selection. All applied voltages in a model are relative to a common ground.

9.18 Charge

Analysis types: Electrostatic

Charge defines an electric charge uniformly distributed across the volume or surface it is applied to. If it is applied to nodes then the specified charge is divided equally between each node.

Charge can be applied to a named selection containing nodes, faces or elements.

9.19 Current

Analysis types: DC Current Flow, Magnetostatic

Current defines an electric current flowing into the model and uniformly distributed across the surface it is applied to. If it is applied to nodes then the specified current is divided equally between each node.

Current can be applied to a named selection containing faces or nodes.

A positive value on the face of an element represents current flowing into the element. In 2D magnetostatic analysis the current only flows parallel to the Z axis. Here a positive value on a node represents current flowing in the positive Z direction.

A winding of many turns in magnetostatic analysis can be modelled by a single current whose value is the sum of the currents in all the turns.

9.20 Magnetic Vector Potential

Analysis types: Magnetostatic

A magnetic vector potential boundary condition constrains the Z-component of the vector potential to the specified value over the faces or nodes that it is applied to. This is a Dirichlet boundary which has the effect of preventing flux lines from crossing the boundary. It can be used on the outside boundary to contain the flux within the domain.

Magnetic vector potential can only be applied to named selections containing faces or nodes.

9.21 Convection

Analysis types: Thermal

Convection allows heat flow into or out of a face according to a specified heat transfer coefficient and ambient temperature.

Convection can only be applied to a named selection containing faces.

9.22 Radiation

Analysis types: Thermal

Radiation allows heat flow into or out of a face according to a specified emissivity and ambient temperature. The Stefan-Boltzmann constant must also be specified in the model.

If radiation is used then all temperatures in the model must be specified in absolute units such as kelvin or degrees Rankine.

Radiation can only be applied to a named selection containing faces.

9.23 Robin Boundary Condition

Analysis types: DC Current Flow, Electrostatic, Magnetostatic

The Robin Boundary Condition imposes the following equation on a face

$$k \frac{\partial u}{\partial n} + c_0 u + c_1 = 0$$

where

- u is the degree of freedom, either electric potential or magnetic potential depending on the analysis type
- k is either the electrical conductivity, absolute permittivity or absolute permeability of the material
- $\partial u/\partial n$ is the normal derivative of u at the face
- c_0 and c_1 are user specified parameters. If $c_0 = 0$ this is a Neumann boundary condition, constraining the field value's gradient normal to the face.

A Robin Boundary Condition can only be applied to a named selection containing faces.

9.24 Cyclic Symmetry

Analysis types: Static 3D, Modal Vibration 3D Solid and Truss, Thermal Steady State

If geometry and loading are regularly repeated about an axis of rotation, then cyclic symmetry (rotational periodicity) can be used to reduce the model to only one segment, allowing a smaller mesh and improved solver performance.

Two named selections must be specified: one contains the nodes on one of the cut surfaces and the other contains nodes on the other surface. These two sets of nodes must have the same layout so that each node on one surface coincides with one node on the other surface when the segment is rotated.

If displacement constraints are applied to nodes on the cut surfaces, their directions will be rotated from X, Y, Z to radial, circumferential and tangential.

In thermal analysis cyclic symmetry is equivalent to applying coupled DOF between the corresponding pairs of nodes on the cut surfaces.

In static analysis cyclic symmetry is equivalent to applying transformed coordinates to the nodes of the cut surfaces and coupling their degrees of freedom.

In modal vibration analysis cyclic symmetry applies transformed coordinates and couples the degrees of freedom using special complex constraints.[2] This method can find modes which are not cyclically symmetric. The number of modes specified for the solution is not the total number of modes, but the number of modes having the same number of nodal diameters. For example if 5 modes are specified in a model with 7 segments, the solver will find the lowest 5 modes with each of 0, 1, 2 and 3 modal diameters, leading to a total of 20 modes.

9.24.1 Cyclic symmetry tutorial

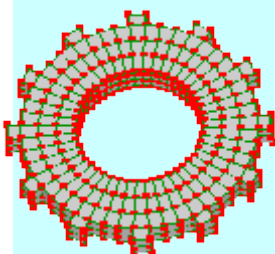

Instead of modeling the entire wheel using solid elements, only one segment will be modeled using cyclic symmetry.

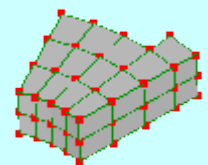

Step 1

Open **CyclicSymmetryTutorial.liml** from the tutorials folder where LISA has been installed.

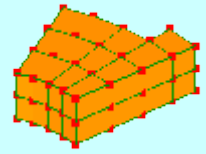

Step 2

Activate **Select nodes** 

Hold the **Ctrl** key down and select these four nodes with the mouse.

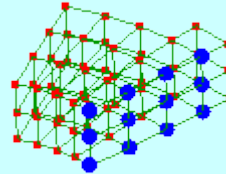

Right click on the selected nodes and select **Add nodes to new named selection**.

Click a blank part of the graphics area to deselect the nodes

Hold the **Ctrl** key down and select these nodes with the mouse.

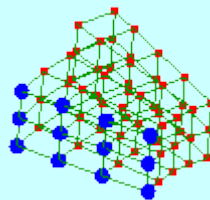

Right click on the selected nodes and select **Add nodes to new named selection**.

Step 3

Right click Loads & Constraints and select **New cyclic symmetry**.



| | |
|-------------------------------|------------|
| Master named selection | Unnamed |
| Slave named selection | Unnamed(2) |
| Axis of symmetry | Y |
| Number of segments | 12 |

Step 4

Select the 3 nodes shown here. Right click on one of the selected nodes and select **Loads & constraints** → **New displacement**.

Axis X
Value 0

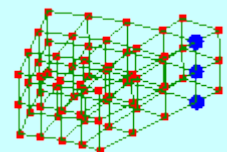

The nodes are now constrained circumferentially and can only move radially and axially.

9.25 Stress Stiffening

Analysis types: Modal Vibration 3D Solid and Truss

The stress state of a structure can influence its stiffness and vibration modes. LISA can account for this by first performing a static analysis to determine the stress state then performing a modal vibration analysis using a modified stiffness matrix.

When Stress Stiffening is applied a static analysis will be run automatically before the modal vibration. Loads should also be applied to induce stress. All the load types available for the corresponding static analysis elements can also be used for stress stiffening except for non-zero displacements.

Tensile stress tends to stiffen a structure and increase the natural frequencies. Compressive stress tends to reduce the frequencies. If compressive stress is too high it may exceed the buckling load of a structure. In these cases LISA may produce non-physical modes with frequencies of "NaN".

9.26 Loads and Constraints on Nodes

Some loads and constraints can be applied to individual nodes instead of named selections. These can allow direct control of the value at each node but they are not interpolated during mesh refinement and are removed by some mesh tools.

To apply these loads or constraints, right click on a node, select **Loads & constraints** then **On selected nodes**. To change their values or delete them select **Edit** from the **On selected nodes** menu. Alternatively, you can select nodes first then right click **Loads & Constraints** in the outline tree then select **On selected nodes**.

9.26.1 rotx, roty, rotz

Analysis types: Static 2D, Static 3D, Modal Response 2D Beam, Modal Response 3D Beam, Modal Vibration 2D Beam, Modal Vibration 3D Shell and Beam, Buckling 2D Beam

Each of these constraints fixes the rotation angle of it's node about the relevant axis (X, Y or Z). The angle is measured in radians. You can only use them on nodes having the corresponding rotational DOFs. This includes nodes of beam and shell elements but not solid or plane continuum elements.

In some analysis types you can also constrain rotation about another axis besides one of X, Y or Z. Do this by rotating the node's coordinate system using transformrx, transformry and/or transformrz.

9.26.2 velx, vely, velz

Analysis types: Fluid Navier-Stokes Equations, Fluid Non-Newtonian Conduit Cross-Section

Each of these constraints fixes one component of a fluid's velocity.

In the Fluid Navier-Stokes Equations analysis type, you can model a no-slip boundary condition by applying velx=0 and vely=0 on all the nodes of the boundary. You can model a symmetry plane by setting only one component to zero to prevent fluid flow through the plane of symmetry. You can model a known flow rate by setting both velx and vely to the two components of the fluid's velocity.

In the Fluid Non-Newtonian Conduit Cross-Section analysis type, you can only use `velz`. This constrains the velocity in the out-of-plane direction. The in-plane (X and Y) velocity components are always zero.

9.26.3 nodepressure

Analysis types: Fluid Navier-Stokes Equations, Acoustic Cavity Modes

In Fluid Navier-Stokes Equations, `nodepressure` constrains the fluid's pressure at the specified node. Only the corner nodes of elements have pressure DOFs, so `nodepressure` applied to midside nodes will be ignored by the solver.

In the Acoustic Cavity Modes analysis type, you can use `nodepressure=0` to enforce a pressure "node". Node here means a location where the pressure remains zero throughout the wave's cycle. Any non-zero value of `nodepressure` will be treated as zero.

9.26.4 startvelx, startvely

Analysis types: Fluid Navier-Stokes Equations

These set initial values of velocity's X and Y components for the iterative solver to begin with. The solution will converge faster if it starts near the solution. They are not typically needed unless you want to optimize the speed or there is an instability which causes the solver to fail to converge otherwise.

9.26.5 velocitypotential

Analysis types: Fluid Potential Flow

`Velocitypotential` constrains the velocity potential on a node. You can create an inlet or outlet by setting zero velocity potential on all the nodes of a boundary. This causes the flow direction to be normal to the boundary.

9.26.6 nodetemperature

Analysis types: Static, Modal Vibration 3D Solid and Truss, Buckling, Thermal

`Nodetemperature` fixes the temperature of a node and is similar to the Temperature load which can be applied to named selections. `Nodetemperature` can be more convenient for a temperature field whose value is different on every node because you can create a large number of them without making a separate named selection and separate outline tree item for every node.

A common use for `nodetemperature` is thermal stress analysis where the values are generated by the solver in a thermal analysis then used as input for a static analysis.

9.26.7 transformrx, transformry, transformrz

Analysis types: Static, Modal Vibration 3D Solid and Truss, Buckling 3D

If you need to constrain displacement or rotation in a direction which is not orthogonal to the X,Y,Z global coordinates then you can rotate the coordinate system of each node. Displacement constraints, rotation constraints (`rotx`, `roty`, `rotz`) and coupled DOF applied to these rotated nodes will be oriented in the new direction.

Transformrx rotates the node's coordinate system about the X axis by the specified number of degrees. Similarly, transformry and transformrz rotate it about the Y and Z axes respectively. You can define an arbitrary orientation by specifying two or all of transformrx, transformry and transformrz on the same node. When more than one rotation is applied to the same node, they are applied in this order: Rotation about Z then rotation about Y then rotation about X.

Inclined supports tutorial

Step 1

Open **InclinedTutorial.liml** from the tutorials folder where LISA has been installed.

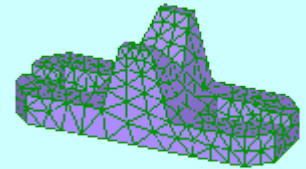

Step 2



Activate **Select nodes** 

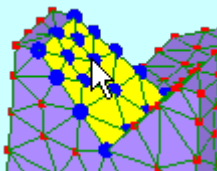

Select the nodes shown here. Right click on one of the selected nodes and select **Loads & constraints** → **On selected nodes** → **New transformrx Value** 45

Step 3

With the nodes of the previous step still selected, right click one of the selected nodes and select **Loads & constraints** → **New displacement**. Click **OK**

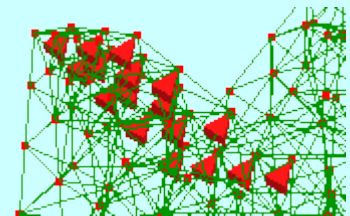

A frictionless sliding support is now enforced along the inclined surface.

9.26.8 mass

Analysis types: Static, Modal Response, Modal Vibration, Dynamic Response, Buckling

Mass is a lumped mass at a node. It can be used instead of density or to idealize a massive object without modeling it with elements. This mass affects dynamic behavior, gravity and centrifugal force. When you apply a mass to several selected nodes, the specified mass is applied to each node and not distributed between them.



9.26.9 rotationalinertiax, rotationalinertiay, rotationalinertiaz

Analysis types: Modal Response 2D Beam, Modal Response 3D Beam, Modal Vibration 2D Beam, Modal Vibration 3D Shell and Beam

These are points of additional rotational inertia about one of the X, Y or Z axes which can only be applied to the nodes of beam and shell elements. You can use them to idealize massive parts such as flywheels without modeling them using elements.

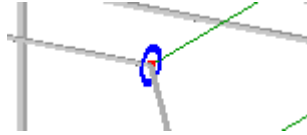

9.27 Coupled DOF

Analysis types: Static 2D, Static 3D, Thermal Steady State, DC Current Flow, Electrostatic, Magnetostatic

This is a form of constraint which forces a DOF (degree of freedom) of a node to have the same value as another DOF of the same or a different node. For example the X-displacement of one node can be coupled to the Y-displacement of another node so they act as if they are connected by a 90° bell crank. In thermal analysis, the temperatures of many nodes can be coupled together to form a perfectly conducting connection.

Each slave DOF can have at most one master, but a master can have any number of slaves. A slave cannot also be a master. Constraints can be applied to either the master or slave DOF of a pair, but not both. Loads can be applied to master, slave or both DOFs of a pair. If applied to both, the two loads are summed.

9.27.1 Coupled DOF tutorial

Step 1

Open **CoupledTutorial.liml** from the tutorials folder where LISA has been installed.

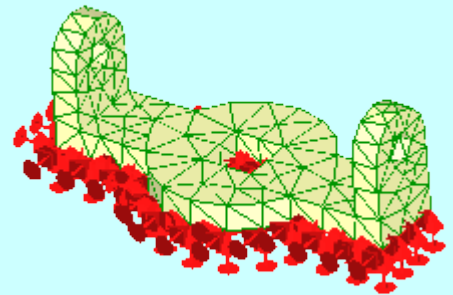

Step 2

Activate **Select nodes** 

Step 3

Right click **Loads & Constraints**  **Loads & Constraints** and select **New coupled DOF**

| | |
|---------------------------|--------------------------------------------------------|
| Master node | 201 |
| Slave node | 36 |
| All matching pairs | <input checked="" type="checkbox"/> check-box selected |

Step 4

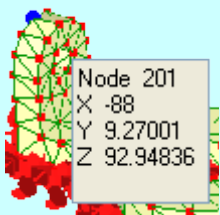

Right click this node and select **Loads & constraints** → **New force**
Named selection Create from current selection
X 100

Step 5

Right click  **Solution** , **Solve**

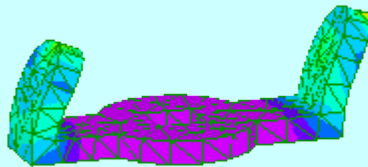

The two coupled nodes have the same displacement as if they are connected by a rigid, non-rotating bar.

9.28 Load Cases

Analysis types: Static

Load cases allow a single computation to be performed for different sets of applied loads instead of having to create separate models for each type of loading. To combine the loads from several load cases you would have to create another load case with the duplicates of the loads in it.

Each load case includes all the loads specified under its branch in the outline tree as well as all loads and constraints specified outside any load case (directly under the Loads & Constraints branch in the outline tree). This allows common loads to be applied to all load cases without being duplicated.

Only the following loads can be used in load cases: force, pressure, line pressure, moment, temperature and nodetemperature. Constraints and gravity can only be common to all load cases.

To create a load case, right click **Loads & Constraints** in the outline tree then select **New load case**.

9.29 Time Dependent Loads

Analysis types: Modal Response, Dynamic Response, Thermal Transient

Some loads and constraints can vary as a function of time. You specify each time-dependent component as a table of time and value pairs. The solver performs a linear interpolation between data points in the table to determine the value at each time step. If a time step is outside the range of times in the table then constant extrapolation is performed so that the final value will be applied at all subsequent times and the first value will be applied at all preceding times.

If a constant value is specified in an analysis type that allows time dependent values then the solver will use the constant value at all time steps.

Results

10.1 Display

- [-] Solution
 - [+] Displacement in X
 - [+] Displacement in Y
 - [+] **Displacement in Z**
 - [+] Stress XX
 - [+] Stress YY
 - [+] Stress ZZ

Select any item below **Solution** to display a field value as a color coded contour plot. These are only available after solving the model.

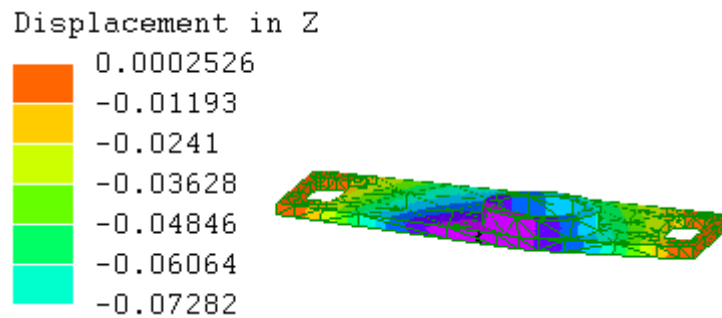

The contour plot can be configured using by selecting **Options** then **Colors** from the **Tools** menu. Here you can change the color scheme, number of colors and resolution. A higher resolution is slower to render but gives smoother boundaries between colors so it can be useful for presentation.

- [+] Stress ZX
- [-] von Mises Stress
 - [+] **Node values**
 - [+] Element values
- [+] Principal Stress 1
- [+] Principal Stress 2

Node values will display the results at each node as the average of the values from all its adjacent elements. This produces a continuous plot.

- ⊕ Stress ZX
- ⊖ von Mises Stress
- Node values
 - Element values
- ⊕ Principal Stress 1
- ⊕ Principal Stress 2

Element values will display the results without nodal averaging. Beam element results should be viewed without nodal averaging because the values of adjacent elements at joints may be very different so averaging can give meaningless results.

Click on a node to display both its averaged node value and the non-averaged values of all its adjacent elements. If there are time steps in the solution, the timeline will also show a graph of the node's value.

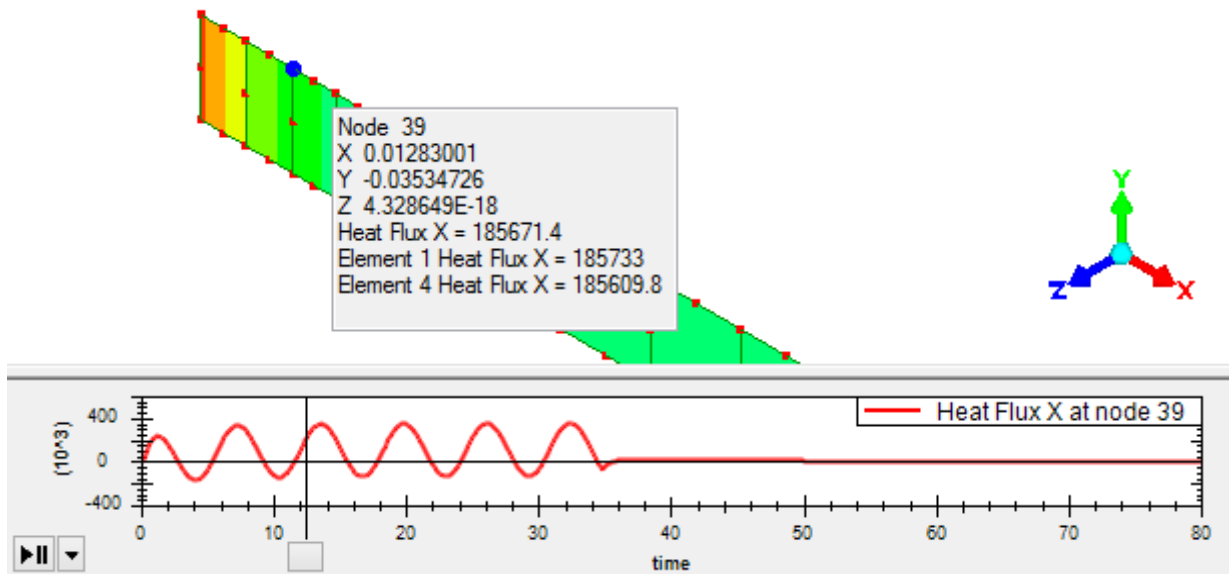

You can control the range of values displayed in the contour plot by selecting **User defined maximum and minimum** from the context menu of **Node values** or **Element values** in the outline tree. Parts of the model outside the specified range will be displayed in black.

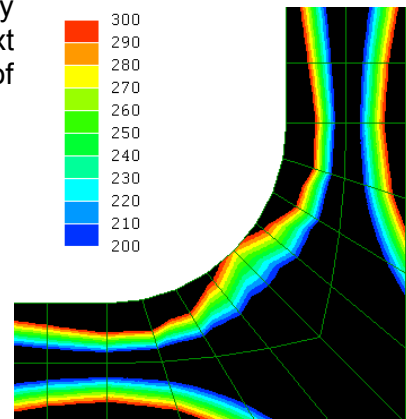

 **View deformed** shows exaggerated deformation. A default amplification factor is chosen automatically to give a clearly visible change. Set this to 1 to show the actual deformation.

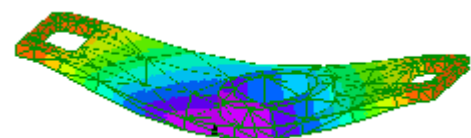



Undeformed mesh on/off superimposes the undeformed profile on the exaggerated deformation.



View undeformed returns to an undeformed display.



Show arrows... displays vector fields using arrows whose length and color correspond to magnitude. This option only works if the selected field value is a vector field magnitude, such as Displacement Magnitude, Velocity Magnitude or Heat Flux Magnitude. You can make the display clearer by turning off **Show element surfaces** and **Show element edges**.

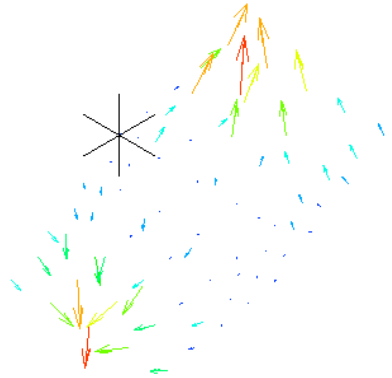

Animation animates the deformation. This only works for results without time steps such as static and modal vibration. For results with time steps such as dynamic response, use the timeline described below.

Time steps in transient problems are displayed on the timeline, the length of which is the total duration of the analysis. The result in the graphic display will correspond to the slider's position.

For example, consider a dynamic response analysis with **Number of time steps = 12** and **Time step = 0.28s**. The length of the horizontal scale would be $12 \times 0.28s = 3.36s$.

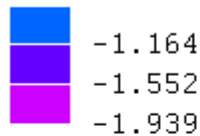

Time = 0.56
Time/60 = 0.009333333

Slider position corresponds to 0.56 sec into the 3.36 sec total time of the analysis. It can also be understood as $0.56/0.28 = 2$ or the second of the 12 time-steps.

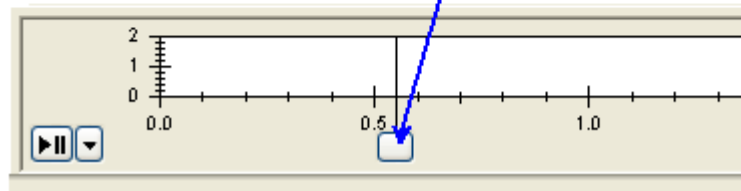

To animate the display, click the play/pause button. The drop-down menu can be used to control the speed. You can use this together with **View deformed** to show movement.

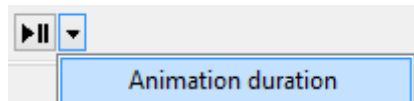

Table displays the results in a table which can be copied and pasted into a spreadsheet. The options you set here are saved with the model so you can easily generate the same table after solving again. If you enter a file name under **Write to csv file after solving** LISA will save the table to the

specified text file every time it solves the model. This file can be opened with a spreadsheet application or other software for further processing.

10.2 File Output

Various results can be written to files when the solver runs. Most of these options are available through the **Output Files** tab in the **Analysis** item in the outline tree. However, to write the solution data in tabulated form to a csv file, use the **Table** item under the **Solution** branch of the outline tree. This is described in the previous section.

Write solution to liml file saves the solution to the specified file. This file may not contain the complete original model, only the solution and supporting information so it can be opened again by LISA.

Write stiffness matrix to file saves the stiffness matrix to a text file. It can be stored in either a sparse or dense format. The **Dense** format contains the entire square matrix with one row on each line of the file. The **Sparse** format doesn't contain most of the zero elements and has only the upper triangle of the symmetric matrix. Each line of the file contains 3 numbers: the row number, the column number and the value in that location of the matrix.

Write mass matrix to file saves the mass matrix with the same two format options as the stiffness matrix.

Write load vector to file saves the global load vector to a file with the value at each DOF on a separate line. If the model contains load cases, the load vectors for each load case are on the same lines separated by commas.

Write DOF reordering to file saves the relationship between global DOF numbers and the row numbers of the matrix. This is only useful in analysis types that use the eigenvalue solver: modal vibration, modal response, acoustic and buckling. A node's global DOF number can be calculated from $(\text{node number} - 1) \times \text{DOFs per node} + \text{node DOF number}$. For example, in the Modal Vibration 3D Solid and Truss analysis type there are 3 DOFs per node so the global DOF for displacement in Y on node 5 would be $(5-1) \times 3 + 2 = 14$. Each line of the file contains the matrix row number corresponding to the global DOF of that line. Where the global DOF has been condensed out of the matrix, the file shows 0 for the matrix row number.

Samples and Verification

11.1 BeamBendingAndTwisting.liml

Analysis type: Static 3D

Elements: Beam (line2)

Loads and constraints: Fixed support, Force, Moment

This sample shows LISA finding the longitudinal stresses due to bending of a beam using a predefined cross-section. It also shows torsional stiffness and that torsion does not influence longitudinal stress. The beam is made from a hollow rectangular tube with properties:

Width: $a=23\text{mm}$

Height: $b=50\text{mm}$

Wall thickness: $t=2\text{mm}$

Length: $l=2\text{m}$

Young's modulus: $E=200\text{GPa}$

Poisson's ratio: 0.3

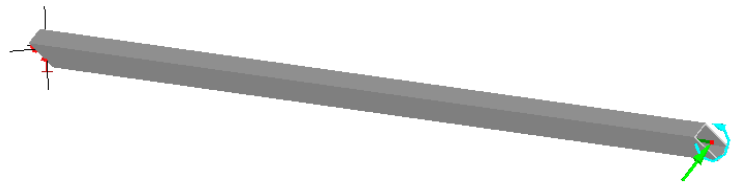

The beam is oriented at 45 degrees to the Y axis and is fully constrained at one end and loaded at the other end with a lateral force of 1N and a twisting moment of 2Nm.

LISA reports stress at 5 locations on the cross-section: each of the four outer corners and a user defined point p on an inside corner. These results are compared to hand calculations below.

The longitudinal stress at the base of the beam at point 1 ($W_1 = 12.5\text{mm}$) should be

$$\sigma_1 = \frac{M_V W_1}{I_{VV}} = 0.844490 \text{ MPa}$$

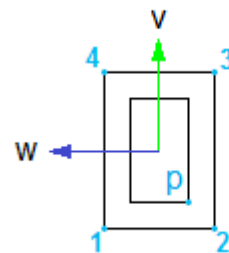

The longitudinal stress at the user defined point p ($W_p = -10.5\text{mm}$) should be

$$\sigma_p = \frac{M_V W_p}{I_{VV}} = -0.709372 \text{ MPa}$$

The bending moment about the V axis (M_V) is $2m \times 1N = 2Nm$. The 2nd moment of area about the V axis (I_{VV}) can be found using a readily available formula and the parallel axis theorem:

$$I_{VV} = 29603 \frac{2}{3} mm^4$$

LISA shows the same stress values:

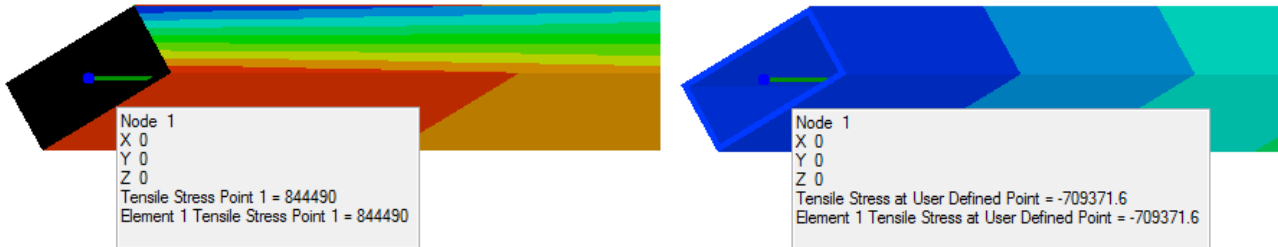

The twisting angle can be found using

$$\theta = \frac{lT}{GJ}$$

where l is the beam length (2m), T is the applied torque (2Nm), G is the modulus of rigidity ($\frac{200}{2.6} GPa$), and J is the torsion constant which is approximated by [3]

$$J \approx \frac{2t(a-t)^2(b-t)^2}{a+b-2t} = 6.86657 \times 10^{-8} m^4$$

This gives $\theta = 7.5729 \times 10^{-4}$ radians which is the same as the twist angle found by LISA because LISA uses the same approximate formula for J .

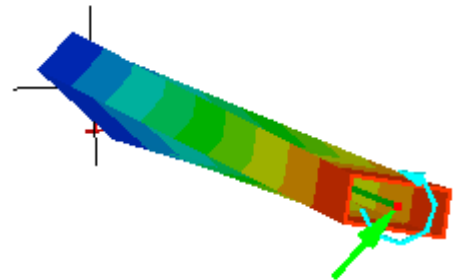

11.2 CylinderLifting.liml

| |
|---------------------------------------------------------------------|
| Analysis type: Static 3D |
| Elements: Shell (tri6, quad8) |
| Loads and constraints: Fixed support, Gravity, Pressure, Load cases |

This sample shows the use of shell elements for a pressure vessel in two different load cases – self weight under gravity, and the same with an additional internal pressure load. It also uses material of different thickness for the end caps.

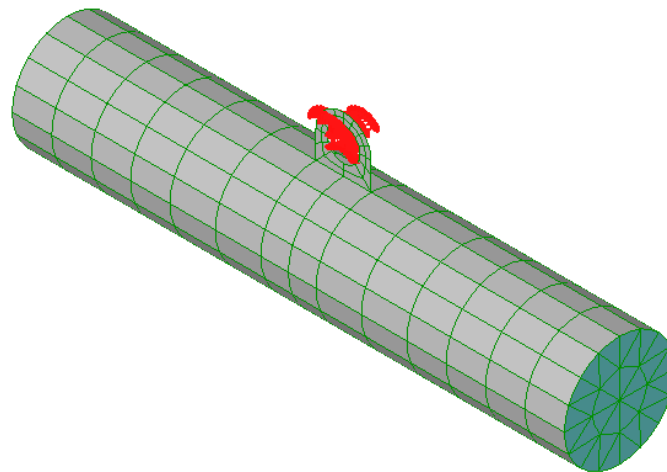

von Mises Stress, Bottom Surface

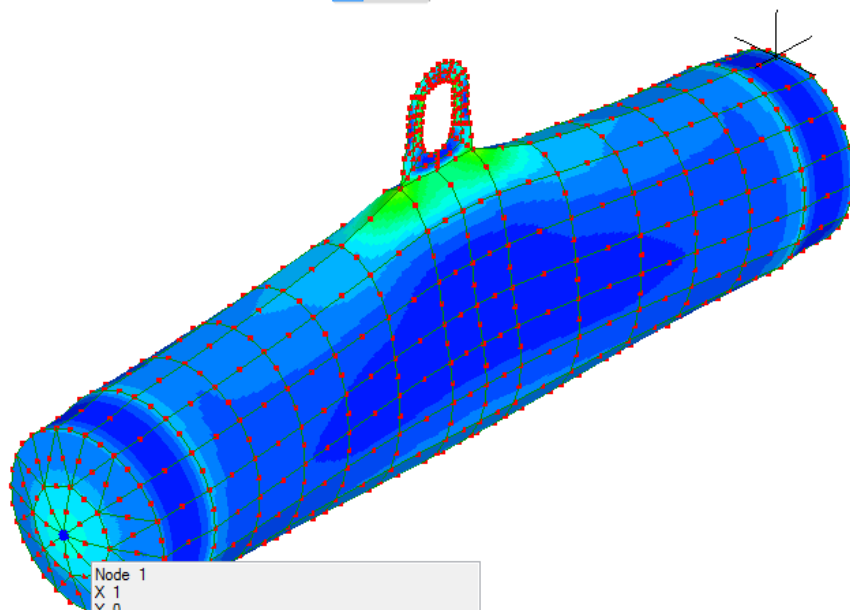
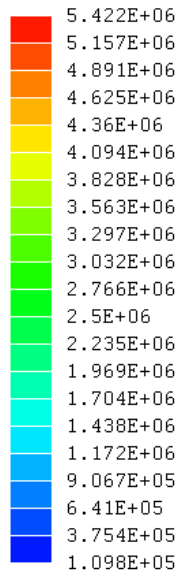

| |
|--------------------------------------------------------|
| Node 1 |
| X 1 |
| Y 0 |
| Z 0 |
| von Mises Stress, Bottom Surface = 1640983 |
| Element 200 von Mises Stress, Bottom Surface = 1641847 |
| Element 204 von Mises Stress, Bottom Surface = 1639998 |
| Element 208 von Mises Stress, Bottom Surface = 1639960 |
| Element 212 von Mises Stress, Bottom Surface = 1642125 |
| Element 216 von Mises Stress, Bottom Surface = 1642125 |
| Element 220 von Mises Stress, Bottom Surface = 1639960 |
| Element 224 von Mises Stress, Bottom Surface = 1639998 |
| Element 228 von Mises Stress, Bottom Surface = 1641847 |

In the pressure load case, the von Mises equivalent stress on the outside surface at the center of each end cap is 1.64×10^6 Pa. Mesh refinement to 16 times the number of elements shows this stress to be in error by about 2%. The outside surface is called the bottom surface in the solution. You can see this by turning on **Show element axes** to show the direction of the blue W axis of each element.

11.3 PressureVesselAxisymmetric.liml

Analysis type: Static axisymmetric

Elements: Axisymmetric continuum (quad8)

Loads and constraints: Displacement, Pressure

This is a cylindrical pressure vessel with semi-ellipsoidal ends. It is modeled as axi-symmetric because the geometry and loads all have axial symmetry about the longitudinal axis. Only one half is modeled due to mirror symmetry and a displacement constraint in the Y direction is applied to enforce this boundary condition.

It is made from steel ($E=200\text{GPa}$, $\nu=0.3$) with wall thickness $t=20\text{mm}$, inside radius $r=500\text{mm}$ and internal pressure $P=1\text{MPa}$.

Three tests are used to validate the results:

The longitudinal reaction force in the cylindrical wall at the mirror symmetry boundary is

$$F_Y = -P \times \pi r^2 = -785\text{kN} \text{ compared to LISA's } -798 \text{ kN}$$

The axial stress in the cylindrical wall is

$$\sigma_{YY} = \frac{F_Y}{\pi((r+t)^2 - r^2)} = 12.25\text{MPa} \text{ compared to LISA's } 12.44 \text{ MPa}$$

The hoop stress in the middle of the cylindrical wall is

$$\sigma_{ZZ} = \frac{Pr}{t} = 25.00\text{MPa} \text{ compared to LISA's } 25.00 \text{ Mpa}$$

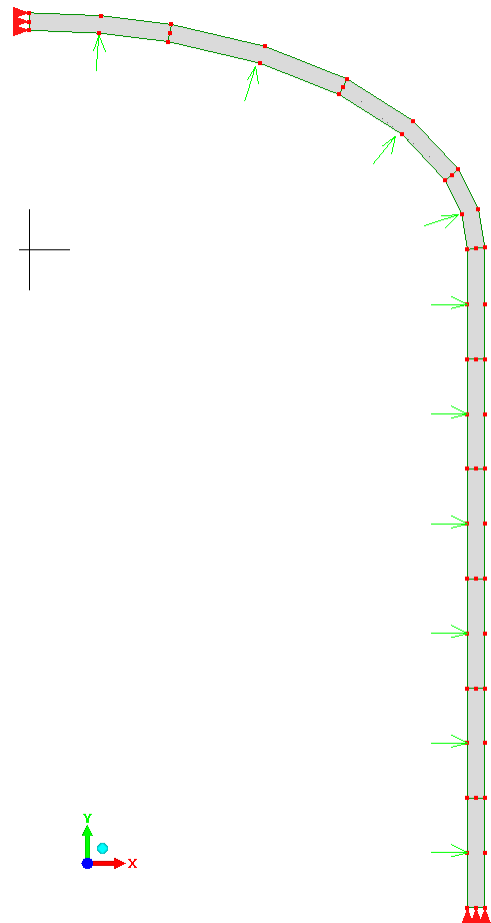

11.4 TwistedBeam.liml

Analysis type: Static 3D

Elements: Shell (quad9)

Loads and constraints: Fixed support, Force

This sample demonstrates a popular test case where LISA's shell elements fail to produce results because they are warped. It is a cantilever beam with a 90° twist along its length and a point load at the free end.

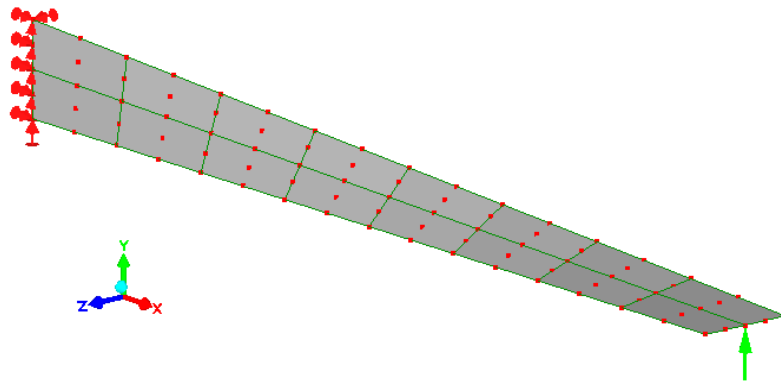

The graph below shows that as the mesh is refined, the displacement at the tip increases in proportion to the number of nodes. It does not converge to a solution. The first data point with 85 nodes is the solution from the sample pictured above without any mesh refinement.

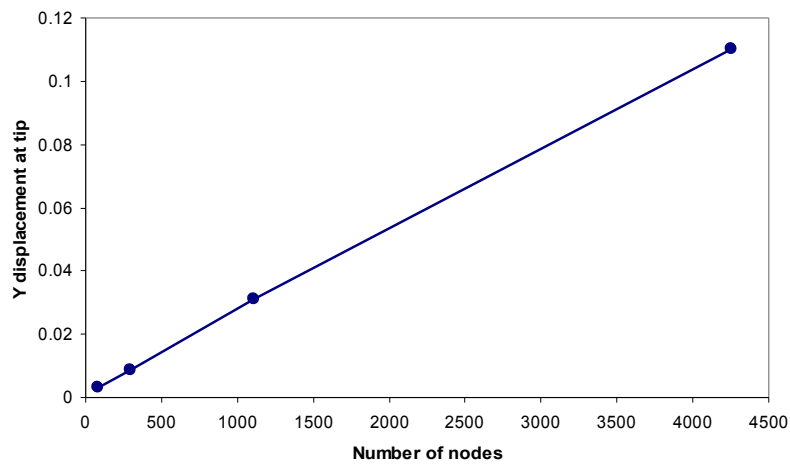

Failure to converge with mesh refinement

11.5 BucklingBeam.liml

Analysis type: Buckling 2D Beam

Elements: Beam (line2)

Loads and constraints: Fixed Support, Force

Consider a column fixed at the base and free at the top, subject to an axial compressive force. We will find the value of the force at which it buckles, the critical load.

The column is of length $L=100\text{mm}$, the cross section is a $10\text{mm}\times 10\text{mm}$ square and the Young's modulus is $E=200,000\text{ N/mm}^2$.

The model is made with line2 elements. The bottom face has a fixed support to constrain displacement and rotation. A point load of 1N has been applied at the top.

The Euler buckling equation is used to calculate the critical load:

$$P_{cr} = \pi^2 E I / (K L)^2$$

$K = 2$ for these boundary conditions

$E = 2 \times 10^5 \text{ N/m}^2$

$I = 833.333 \text{ mm}^4$

$L = 100 \text{ mm}$

Critical load, $P_{cr} = 41123 \text{ N}$



The buckling factor for mode 1 found by LISA is 41125 and approaches the theoretical value with mesh refinement. This is equal to the buckling load in newtons because a force of 1N was applied in the model. The mode shape shows that this is indeed the first buckling mode.

The shift point is set to 1000 which is typically reasonable being an order of magnitude below the lowest buckling factor.

11.6 BucklingPlate.liml

Analysis type: Buckling 3D Solid and Truss

Elements: Solid continuum (hex20)

Loads and constraints: Displacement, Pressure

Consider a simply supported plate with compressive edge loading on two opposite edges. We will determine the critical loads of lowest few buckling modes.

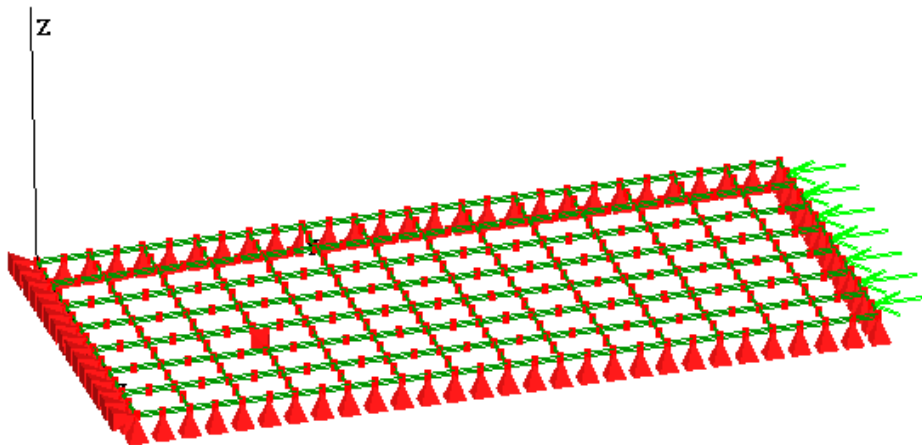

The translational motions along the Z axis are constrained for all the edges, but they are free to rotate about the edge directions. Translational motion in the X-Y plane is allowed, except the bottom edge is restrained to provide a reaction to the applied force. A single arbitrarily chosen node is constrained in the x direction to prevent rigid body motion.

The total applied load is equal to 1, so the buckling factors produced by the solver are equal to the critical loads.

For thin plates such as the one used above, the following analytical equation can be used to calculate the first four critical loads:

$$F_{cr} = b\pi^2 a^2 D ([m/a]^2 + [n/b]^2) / m^2$$

F_{cr} : The critical load applied to one edge

$a=2$: Length in direction of load

$b=1$: Width

$D=E t^3 / [12 (1-\nu^2)]$: Plate rigidity

$t=0.0125$: Thickness

$\nu=0.3$: Poisson's ratio

$E=1e6$: Young's modulus

m : Number of half-waves of the buckle in the direction of the load

n : Number of half-waves of the buckle perpendicular to the load

For $m=1$ and $n=1$, $F_{cr}=11.0$. The LISA model gives 11.1

For $m=2$ and $n=1$, $F_{cr}=7.06$. The LISA model gives 7.11 (pictured below)

For $m=3$ and $n=1$, $F_{cr}=8.29$. The LISA model gives 8.46

For $m=4$ and $n=1$, $F_{cr}=11.0$. The LISA model gives 11.6

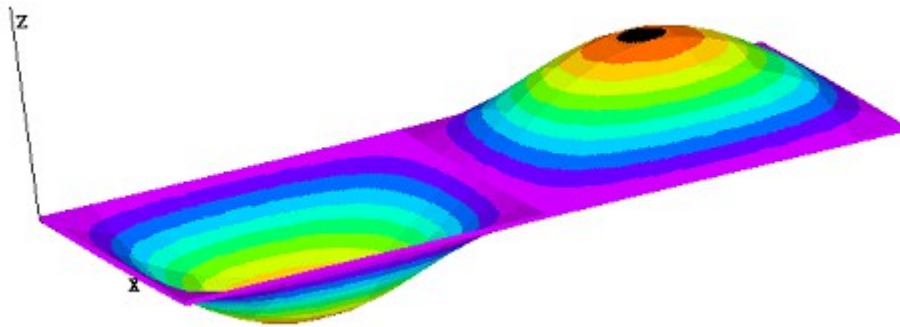

Notice that the lowest critical load is for the mode with 2 half-waves so this mode will develop first under increasing load.

11.7 FinConvection.lim1

Analysis type: Thermal Steady State
 Elements: Fin (line2, line3)
 Loads and constraints: Temperature, Convection

LISA will find the temperature distribution along the length of the thermal fin shown below. Heat enters the base of the fin which is held at a fixed temperature of 230°C and is lost through the 4 sides by convection. The material has thermal conductivity of $k=380\text{W}/(\text{mK})$. The model contains two alternative meshes for the same fin, one using a line3 element and the other using two line2 elements.

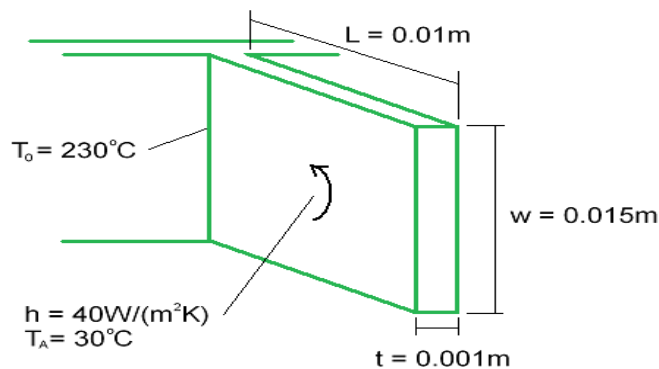

The temperature (T_x) a distance x from the base of the fin is given by

$$\frac{T_x - T_a}{T_0 - T_a} = \frac{\cosh(mL - mx)}{\cosh(mL)}$$

where $m = \sqrt{\frac{hP}{kA}}$

P is the perimeter of the cross-section, 0.032m

A is the area of the cross-section, 0.000015m²

The table below shows close agreement between LISA's results and the temperatures given by the above formula.

| Location | T _x from the formula | 2×line2 elements | 1×line3 element |
|------------------------|---------------------------------|------------------|-----------------|
| Midpoint (x=0.005m) | 228.3306°C | 228.3299°C | 228.3306°C |
| End (x=0.01m) | 227.7752°C | 227.7742°C | 228.7752°C |

11.8 ConductionConvectionRadiation.liml

Analysis type: Thermal Steady State

Elements: Shell (quad4), Solid continuum (hex8), fin (line2)

Loads and constraints: Temperature, Convection, Radiation

This model shows one-dimensional steady state heat transfer by conduction, convection and radiation through a slab of thickness 0.05 m. Heat flows in through the left hand surface which is held at 500 K and heat flows out through the right hand surface by both convection (heat transfer coefficient $h = 37.5 \text{ W/(m}^2\text{K)}$) and radiation (emissivity $\epsilon = 0.8$) to an ambient temperature of 300 K.

Three versions of the model are included in the same file, using shell, solid and fin elements. All three give the same results except heat flux is not available for the fin element.

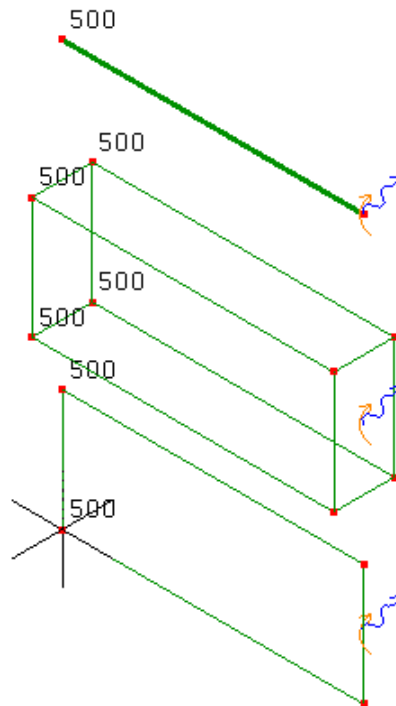

To verify the analysis we will perform a simple heat balance:

$$q_{\text{conduction}} = q_{\text{convection}} + q_{\text{radiation}}$$

Heat flux by conduction ($q_{\text{conduction}}$) is given by LISA as the x component of heat flux which is the same over the entire model

$$q_{\text{conduction}} = 3591.65 \text{ W/m}^2$$

Heat flux by convection is found using the temperature LISA calculated for the right hand face ($T_{\text{surface}}=380.2783\text{K}$)

$$q_{\text{convection}} = h(T_{\text{surface}} - T_{\text{ambient}}) = 3010.44 \text{ W/m}^2$$

Heat flux by radiation is found in a similar way but using the Stefan-Boltzmann law

$$q_{\text{radiation}} = \epsilon\sigma(T_{\text{surface}}^4 - T_{\text{ambient}}^4) = 581.21 \text{ W/m}^2$$

where σ is the Stefan-Boltzmann constant, $5.67037 \times 10^{-8} \text{ Wm}^{-2}\text{K}^{-4}$

The heat balance equation is satisfied:

$$3591.65 \text{ W/m}^2 = 3010.44 \text{ W/m}^2 + 581.21 \text{ W/m}^2$$

11.9 OscillatingHeatFlow.liml

Analysis type: Thermal Transient
 Elements: Shell (quad8)
 Loads and constraints: Heat flow rate

An insulated aluminum bar is heated by an oscillating thermal load applied to one end then removed. LISA will find the temperature in the bar as a function of both time and distance along the bar. The material properties are:

Specific heat capacity, $c_p = 900 \text{ K/(kg.K)}$

Density, $\rho = 2700 \text{ kg/m}^3$

Thermal conductivity, $k = 200 \text{ W/(m.K)}$

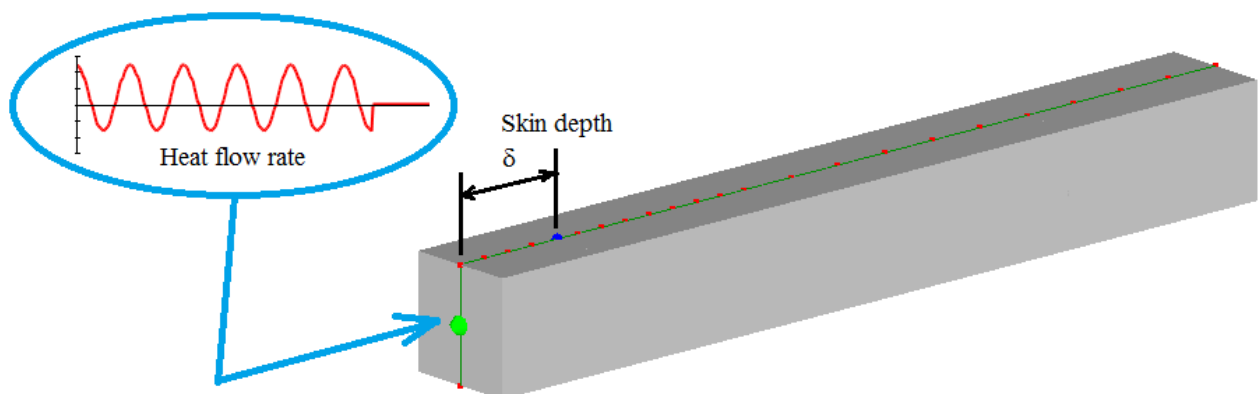

The heat load $Q(t)$ is input into LISA as a table of heat flow rate values every 0.2s according to this function:

$$Q(t) = \begin{cases} (100\cos(t) + 20) W & t \leq 34.6s \\ 0 & t > 34.6s \end{cases}$$

The graph below shows the temperature variation with time at two points. The red curve is measured at the end of the bar ($x=0$) and the green curve is temperature measured at the skin depth ($x=\delta$).

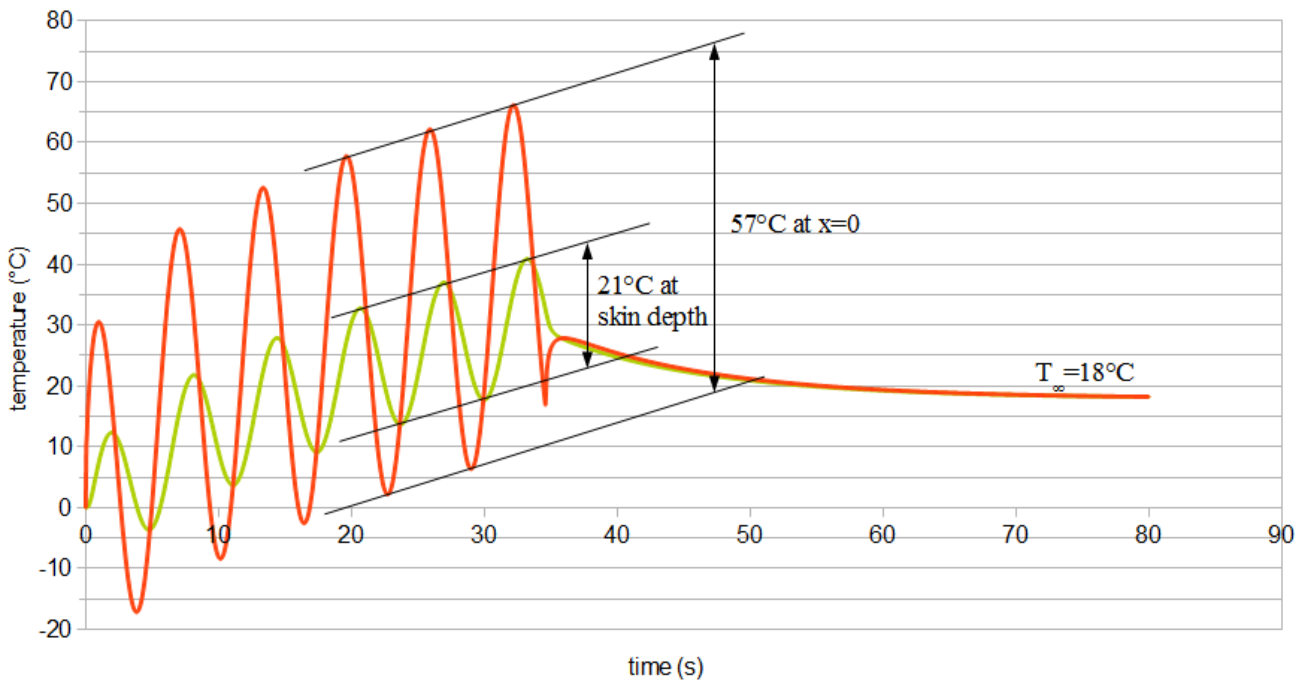

These results are verified in two ways, first by comparing the ratio of the temperature wave amplitudes at two points to their theoretical ratio, and second by comparing the net heat input to the total temperature rise after it has reached equilibrium.

The skin depth δ is the distance at which the amplitude of the temperature variation is $1/e$ of the amplitude at $x=0$. It is given by

$$\delta = \sqrt{\frac{kP}{\rho c_p \pi}}$$

where P is the period of the temperature wave. $P=2\pi$

$$\delta = 0.01283001m$$

A mesh node is located at $x=\delta$ for convenient measurement. The graph above shows the peak-peak amplitude of temperature at this node is 21°C . It also shows the peak-peak amplitude of temperature at $x=0$ is 57°C . $57/20 = 2.85 \approx e$ as required.

The expected temperature rise from $t=0$ to $t=\infty$ is

$$\Delta T = \frac{Q_{net}}{\rho c_p V}$$

$V = \text{volume of the bar} = 1.5625 \times 10^{-5} \text{m}^3$

$$\begin{aligned}
 Q_{net} &= \int_0^{34.6} Q(t) dt \\
 &= \int_0^{34.6} (100\cos(t) + 20) W dt \\
 &= [100\sin(t) + 20t]_a^b J \\
 &= 687.75 J
 \end{aligned}$$

$$\Delta T = 18^\circ C$$

This agrees with the final value of temperature given by LISA across the whole bar which is also $18^\circ C$.

11.10 FluidPipeXSection.liml

Analysis type: Fluid Non-Newtonian Conduit Cross-Section

Elements: Plane continuum (quad4)

Loads and constraints: Pressure Gradient Z, velz

This sample will determine the velocity distribution of a Newtonian fluid flowing in a circular pipe. The pressure gradient of 2000Pa over a pipe length of 1m is 2000 Pa/m. Only one segment of the pipe is modelled due to symmetry. At the outer edge the velocity is constrained to zero representing a no-slip condition.

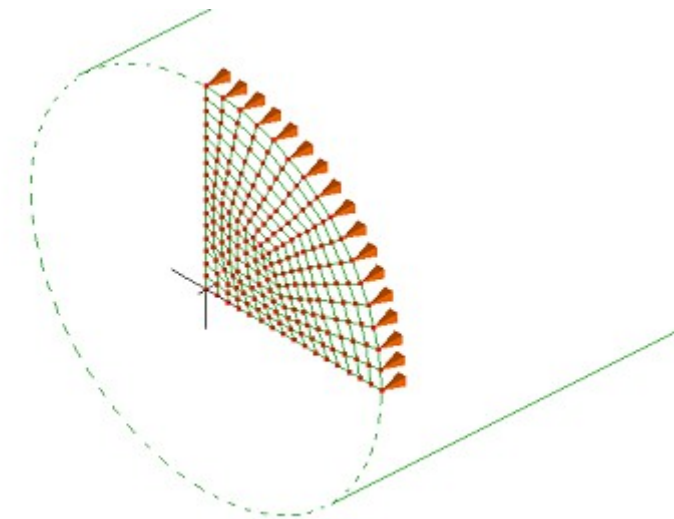

The theoretical velocity distribution is given by

$$V(x) = dP/dZ \times (x^2 - r^2) / (4 \mu)$$

x is the distance from the center of the pipe

dP/dZ is the pressure gradient, -2000Pa/m

r is the radius of the pipe, 0.1m

μ is the dynamic viscosity of the fluid, 12 Pa.s

The table below shows the agreement between LISA's results and the formula.

| X-coordinate | Theoretical velocity | LISA |
|--------------|----------------------|-----------|
| 0 m | 0.417 m/s | 0.414 m/s |
| 0.025 m | 0.391 m/s | 0.388 m/s |
| 0.05 m | 0.313 m/s | 0.310 m/s |
| 0.075 m | 0.182 m/s | 0.180 m/s |
| 0.1 m | 0 m/s | 0 m/s |

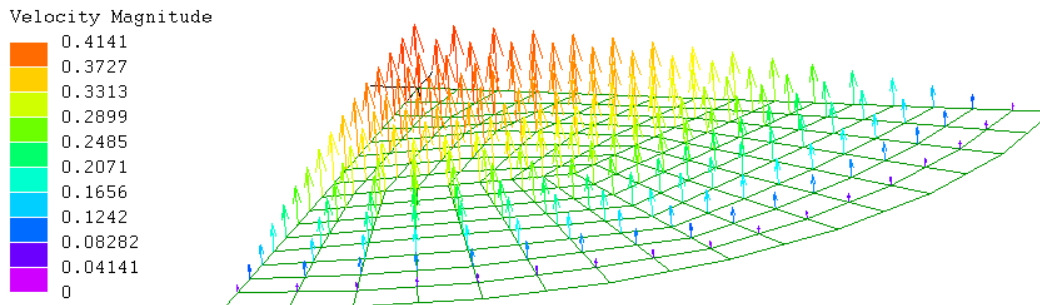

11.11 FluidPseudoplastic.liml

Analysis type: Fluid Non-Newtonian Conduit Cross-Section
 Elements: Plane continuum (quad8)
 Loads and constraints: Pressure Gradient Z, velz

The velocity distribution in a pseudo-plastic fluid flowing between infinite parallel plates will be found by a hand calculation and compared to LISA's results

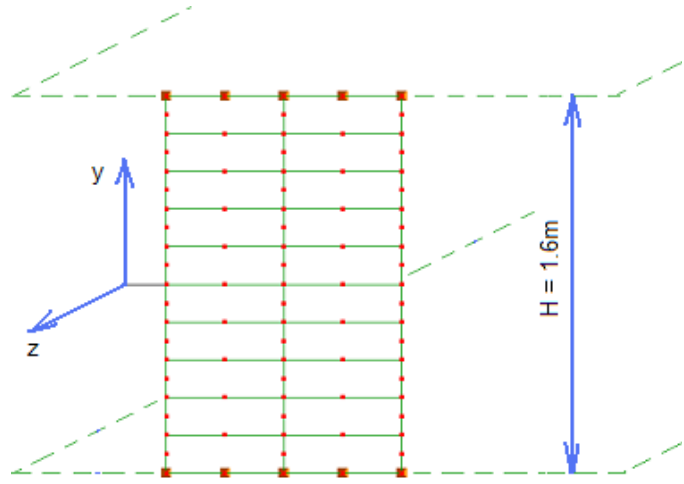

The theoretical velocity profile is given by the following equation [5]

$$V_z(y) = \phi \left(-\frac{dP}{dz} \right)^{\frac{1}{n}} \frac{\left(\frac{H}{2} \right)^{\frac{1}{n}+1} - y^{\frac{1}{n}+1}}{\frac{1}{n}+1}$$

dP/dZ: pressure gradient = -10Pa/m

n = 0.7

ϕ : K = $\phi^n = 1$

H: gap width = 1.6m

y: vertical distance from the center of the gap

| Y-coordinate | Theoretical velocity | LISA |
|--------------|----------------------|-----------|
| 0 m | 6.425 m/s | 6.394 m/s |
| 0.16 m | 6.296 m/s | 6.278 m/s |
| 0.32 m | 5.731 m/s | 5.719 m/s |
| 0.48 m | 4.567 m/s | 4.559 m/s |
| 0.64 m | 2.688 m/s | 2.685 m/s |
| 0.80 m | 0.000 m/s | 0.000 m/s |

11.12 FluidBingham.liml

Analysis type: Fluid Non-Newtonian Conduit Cross-Section

Elements: Plane continuum (quad8)

Loads and constraints: Pressure Gradient Z, velz

The velocity distribution will be found for a Bingham fluid flowing between parallel plates.

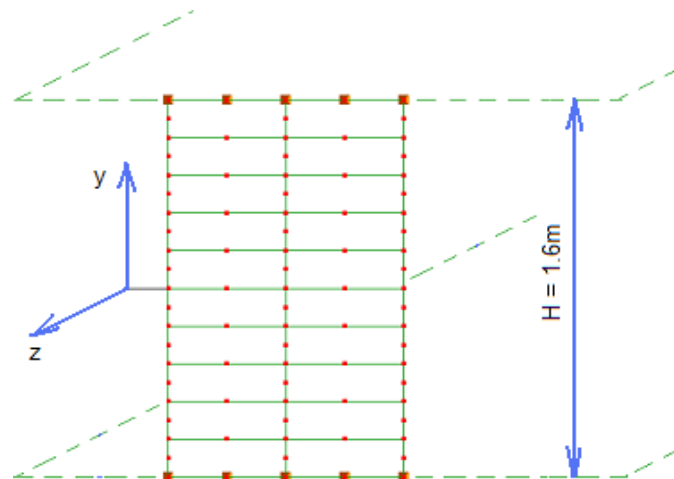

The fluid forms a solid plug in the middle of the channel where the shear stress is less than τ_0 . The expected velocity of this plug is $1.4 \times$ average velocity and the half-width of the plug is [6]

$$h_p = \tau_0 / |dP/dZ|$$

dP/dZ : pressure gradient = -10Pa/m

τ_0 : critical shear stress = 1 Pa

H: gap width = 1.6m

$K = 1$

$n = 1$

The solution shows a plug velocity of 2.45m/s which is $1.43 \times$ the average of 1.71m/s . The velocity profile below shows the plug width of $2h_p = 0.2\text{m}$ which is consistent with the theoretical value from the formula above.

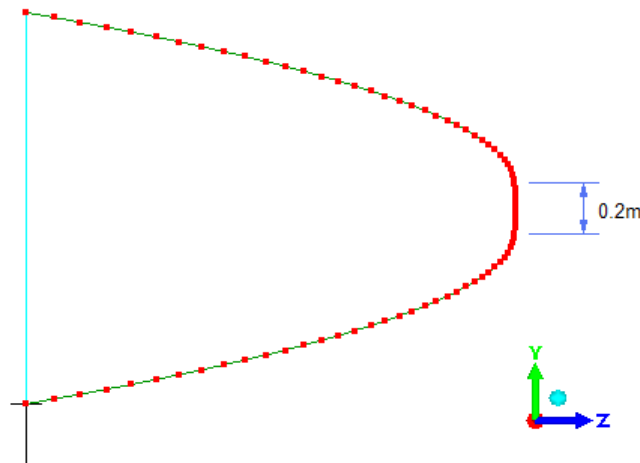

11.13 FluidPotentialCylinder.liml

Analysis type: Potential Flow 2D

Elements: Plane continuum (tri3, quad4)

Loads and constraints: Flow rate, velocitypotential

LISA will be used to analyze the flow of water ($\rho=1000\text{kg/m}^3$) around a cylinder of radius $R=0.1\text{m}$. The flow is assumed to be incompressible, inviscid and irrotational.

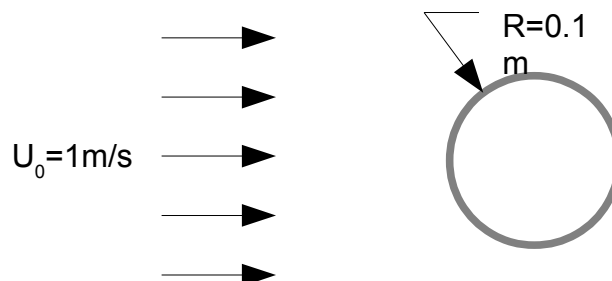

The mesh is made of only one quadrant by taking advantage of symmetry. Velocity potential is set to zero along the midplane of the cylinder because this plane will be perpendicular to the flow direction. A

flow rate of 3m³/s is applied to the 3m² inlet surface to give a uniform velocity of U₀=1m/s over the surface.

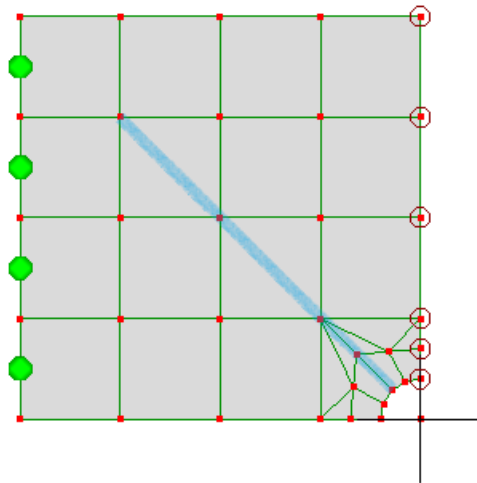

The table below compares the solution values with theoretical formulas along the $\theta=45^\circ$ line shown in blue in the above picture.

| Radius r | Velocity potential ϕ (m ² /s) | | Velocity magnitude U (m/s) | | Dynamic pressure (Pa) | |
|----------|-----------------------------------------------|-------|--------------------------------|-------|-----------------------|------|
| | $U_0(r + \frac{R^2}{r})\cos(\theta)$ | LISA | $\sqrt{U_0 + \frac{R^4}{r^4}}$ | LISA | $\frac{\rho U^2}{2}$ | LISA |
| 0.1000 | 0.141 | 0.131 | 1.414 | 1.404 | 1000 | 988 |
| 0.2268 | 0.192 | 0.189 | 1.019 | 1.048 | 519 | 555 |
| 0.3536 | 0.270 | 0.271 | 1.003 | 1.037 | 503 | 541 |
| 0.7071 | 0.510 | 0.513 | 1.000 | 1.012 | 500 | 512 |
| 1.0607 | 0.757 | 0.762 | 1.000 | 1.006 | 500 | 506 |

11.14 FluidStep.liml

Analysis type: Fluid Navier-Stokes Equations 2D

Elements: Plane continuum (quad8)

Loads and constraints: velx, vely, nodepressure

Flow of viscous fluid over a backward facing step is analyzed. Dynamic viscosity = 0.00457, and density=1.0.

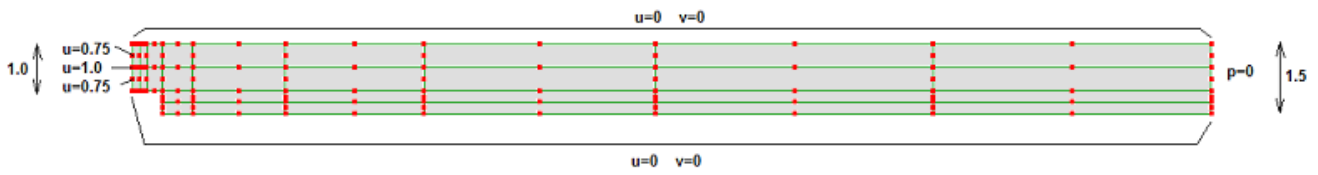

The velocity results match those published in [1] including those derived from experiment. An eddy is visible immediately downstream of the step.

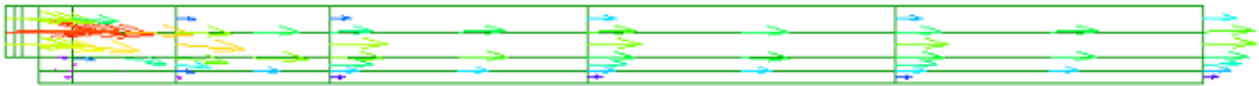

11.15 FluidCouette.lim1

Analysis type: Fluid Navier-Stokes Equations 2D

Elements: Plane continuum (tri6)

Loads and constraints: velx, vely, nodepressure

Here an analysis is done for fully developed flow between parallel plates with the lower plate fixed and the upper plate moving parallel to it with a constant velocity $U=3\text{m/s}$. The flow is driven both by the plate movement and an applied pressure gradient of -0.25Pa/m . This kind of flow is commonly known as Couette flow.

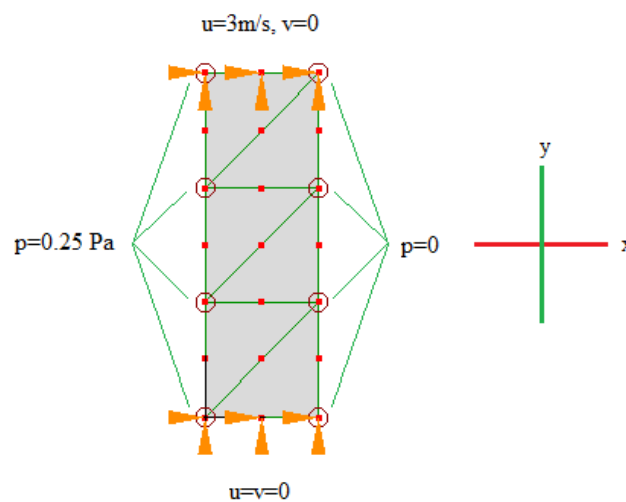

The theoretical velocity profile is parabolic, which can be represented exactly by the quadratic tri6 elements so the x-components of velocity from LISA are identical to the theoretical values found from [1]:

$$u(y) = \frac{U}{h} \left(y + \frac{h}{2} \right) - \frac{1}{2\mu} \frac{\partial p}{\partial x} \left(\frac{h^2}{4} - y^2 \right)$$

where

$$U = u(1.5) = 3 \text{ m/s}$$

$$h = \text{height} = 3 \text{ m}$$

$$\mu = \text{dynamic viscosity} = 0.1 \text{ Pa}\cdot\text{s}$$

$$\frac{\partial p}{\partial x} = \text{pressure gradient} = -0.25 \text{ Pa/m}$$

| y (m) | u(y) from formula (m/s) | u(y) from LISA (m/s) |
|-------|-------------------------|----------------------|
| -1.5 | 0 | 0 |
| -0.5 | 3.5 | 3.5 |
| 0 | 4.3125 | 4.3125 |
| 0.5 | 4.5 | 4.5 |
| 1.5 | 3 | 3 |

11.16 FluidViscousCylinder.liml

Analysis type: Fluid Navier-Stokes Equations 2D

Elements: Plane continuum (quad8)

Loads and constraints: velx, vely, nodepressure, startvelx, startvely

Rotational laminar flow around a cylinder is analyzed. This example has been taken from [1]. Dynamic viscosity = 0.1 and density = 1. The Reynolds number is 20 which is expected to lead to the boundary layer separating into two steady, symmetrical eddies downstream of the cylinder. Only one will appear in the solution because only one half of the cylinder is modeled.

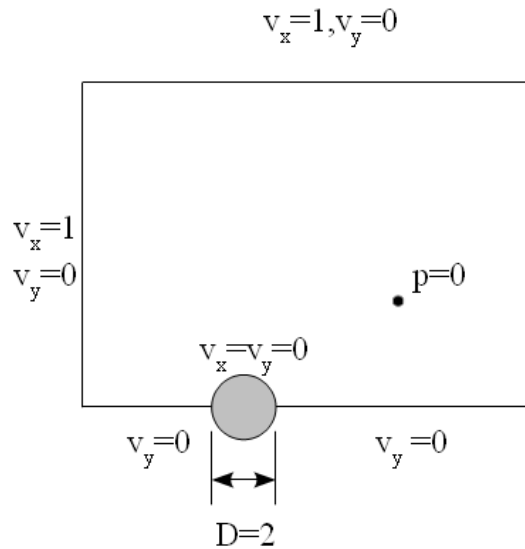

At the upper and left boundary, the fluid velocity in x (velx) is set to 1 and the fluid velocity in y is zero to represent uniform flow a large distance from the cylinder. At the lower boundary, the y component of velocity (vely) is set to zero to enforce symmetry. On the surface of the cylinder, both components of velocity are zero because it has a no-slip boundary condition.

Start velocities which are close to the final values have been specified to speed up the solution. These are not required for this problem and it will converge to within about 1% of the same solution without them.

The table below shows the close agreement between LISA's results and those published in Taylor and Hughes [1]:

| Node number | Source | velocity x | velocity y | pressure |
|-------------|-----------------|------------|------------|----------|
| 236 | Taylor & Hughes | 0.404 | 0.000 | 0.00173 |
| | LISA | 0.404 | 0.000 | 0.00173 |
| 237 | Taylor & Hughes | 0.414 | -0.0101 | - |
| | LISA | 0.414 | -0.0101 | - |
| 238 | Taylor & Hughes | 0.442 | -0.0187 | 0.00211 |
| | LISA | 0.442 | -0.0187 | 0.00211 |
| 243 | Taylor & Hughes | 1.12 | -0.0215 | - |
| | LISA | 1.12 | -0.0215 | - |
| 244 | Taylor & Hughes | 1.08 | -0.0159 | -0.0113 |
| | LISA | 1.08 | -0.0159 | -0.0113 |

11.17 VibratingFreePlate.liml

Analysis type: Modal Vibration 3D Shell and Beam

Elements: Shell (quad8)

Loads and constraints: none

This sample shows the undamped natural vibration modes of a square plate without any supports. Its properties are:

Side length, $a = 0.1\text{m}$

Thickness, $h = 1\text{mm}$

Young's modulus $E = 200\text{ GPa}$

Poisson's ratio, $\nu = 0.225$

Density, $\rho = 8000\text{ kg/m}^3$

The first three deformation modes found by LISA are shown below along with their angular frequencies. LISA also produces 6 rigid body modes because the plate is unconstrained.

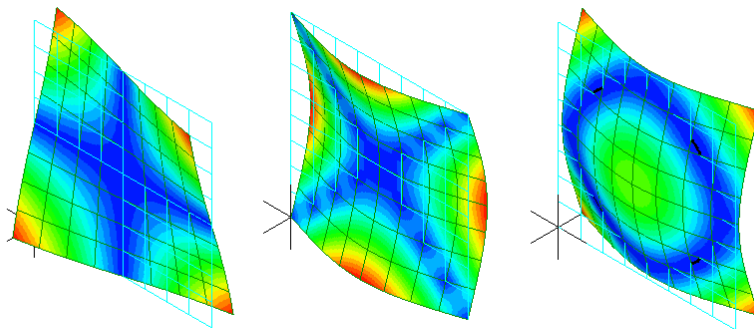

$\omega_1 = 2114\text{ rad/s}$

$\omega_2 = 3122\text{ rad/s}$

$\omega_3 = 3662\text{ rad/s}$

These results are verified by comparison with analytical formulas [7]:

$$\omega = \frac{\alpha}{a^2} \sqrt{\frac{D}{\rho h}}$$
$$D = \frac{Eh^3}{12(1-\nu^2)}$$

$\alpha_1 = 14.10$, $\omega_1 = 2089\text{ rad/s}$

$\alpha_2 = 20.56$, $\omega_2 = 3046\text{ rad/s}$

$\alpha_3 = 23.91$, $\omega_3 = 3542\text{ rad/s}$

For all three modes the error is less than 4% and can be reduced to less than 1% with mesh refinement.

11.18 VibratingCantileverBeam.liml

Analysis type: Modal Vibration 3D Shell and Beam

Elements: Beam (line2)

Loads and constraints: Fixed support

Beam elements are used to model a vibrating cantilever fixed at one end and free at the other. Four elements are needed to capture the higher bending modes. The beam's properties are:

Length, $L = 2.4\text{m}$

Width, $b = 0.1\text{m}$

Height, $h = 0.05\text{m}$

Young's modulus, $E = 200\text{ GPa}$

Density, $\rho = 7860\text{ kg/m}^3$

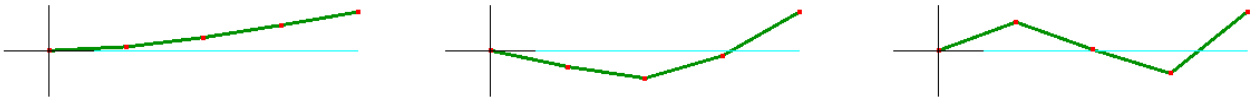

The frequencies of the first 3 modes for bending in the XY plane are verified by the formula

$$f_n = \frac{\alpha^2}{2\pi} \sqrt{\frac{EI}{\rho b h L^4}}$$

$$\alpha_1 = 1.875$$

$$\alpha_2 = 4.694$$

$$\alpha_3 = 7.885$$

$$I = \frac{bh^3}{12} = 2.0833 \times 10^{-6} \text{ m}^4$$

which gives these frequencies compared to LISA

| Mode | Frequency from formula | Frequency from LISA |
|------|------------------------|---------------------|
| n=1 | 7.073 Hz | 7.074 Hz |
| n=2 | 44.33 Hz | 44.38 Hz |
| n=3 | 125.1 Hz | 125.1 Hz |

11.19 VibratingCantileverSolid.liml

Analysis type: Modal Vibration 3D Solid and Truss

Elements: Solid continuum (hex20)

Loads and constraints: Fixed support

This is a model of the same beam described in VibratingCantileverBeam.liml but it is made using hex20 solid elements. The picture below shows the same mode shapes that are shown for VibratingCantileverBeam.liml.

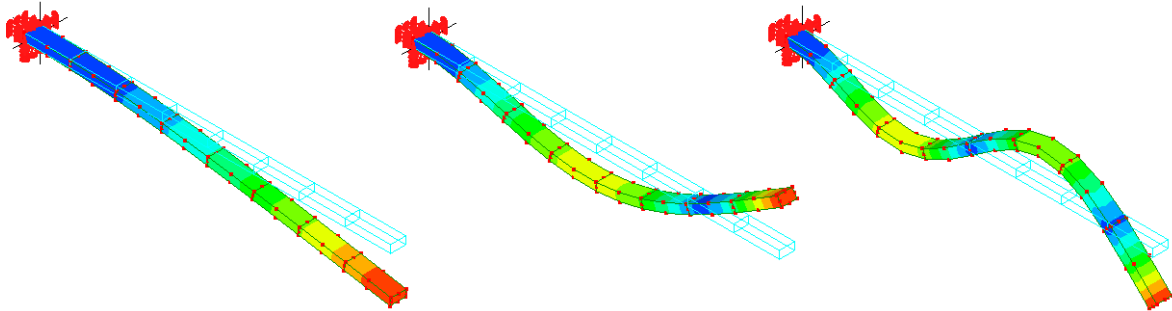

| Mode | Frequency from formula | Frequency from LISA |
|------|------------------------|---------------------|
| n=1 | 7.073 Hz | 7.089 Hz |
| n=2 | 44.33 Hz | 44.99 Hz |
| n=3 | 125.1 Hz | 128.7 Hz |

11.20 VibratingTrussTower.liml

Analysis type: Modal Vibration 3D Solid and Truss, Static 3D

Elements: Truss (line2)

Loads and constraints: Displacement, Force

A truss tower will be analyzed to find the fundamental torsional vibration mode. It is 20m high and made from 10 identical 1m×1m×2m sections connected end to end. Each section uses two types of steel beam – the chords at the corners have 0.01m² cross sectional area and the bracing members have 0.001m² cross sections. All joints are free to rotate in any direction. The steel's Young's modulus is 200GPa and density is 7800kg/m³. The 4 nodes at the base are constrained against displacement in all directions.

The first two modes found by LISA are bending modes and the 3rd is the fundamental torsion mode shown below with frequency

$$f_{\text{LISA}} = 7.64 \text{ Hz.}$$

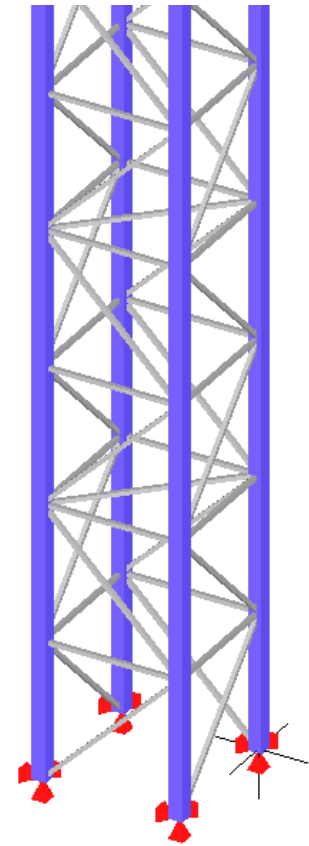
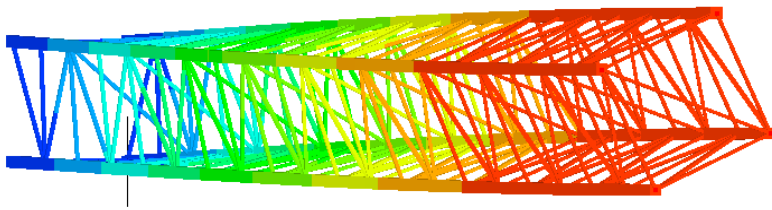

This result is validated using the formula for the fundamental torsion mode of a uniform shaft with distributed mass

$$f = \frac{1}{4} \sqrt{\frac{K}{I}}$$

$I = 3640.54 \text{ kgm}^2$ is the rotational inertia of the whole structure about its longitudinal axis. It can be found by summing the rotational inertia of all 250 truss elements.

K is the torsional stiffness of the structure. This is found by using LISA to perform a static analysis with an applied torque of 1Nm then measuring the resulting rotation at the end. The torque is applied using 4 forces on the top 4 nodes. If you change the analysis type to Static 3D then solve it, it will show the top nodes each rotate by $\theta = 2.92843 \times 10^{-7}$ radians about the longitudinal axis of the tower. This gives $K = 1\text{Nm} / \theta = 3.41480 \times 10^6 \text{ Nm/radian}$.

The frequency given by this formula matches LISA's result to within 0.3%.

$$f = 7.66 \text{ Hz}$$

11.21 VibratingMembrane.liml

Analysis type: Modal Vibration 2D Transverse Vibration of Membrane

Elements: Plane continuum (tri3)

Loads and constraints: Fixed Support, Tension per Length

A hexagonal sheet of fabric is fixed around its outer edge and held in a state of uniform isotropic bi-axial tension. It can vibrate like a drum head due to the stiffness caused by its tension. We will find its first 3 natural frequencies and mode shapes.

Density: 1000kg/m³

Thickness: 1mm

Distance between opposite corners: 600mm

Tension per unit length: 2N/m

The results shown below closely match the results from the sample VibratingMembraneCyclicSymmetry.liml which is the same problem analyzed using solid elements.

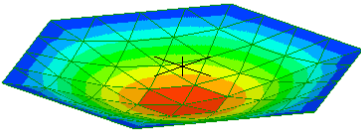
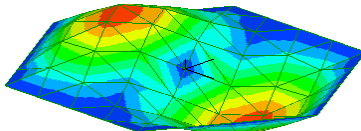
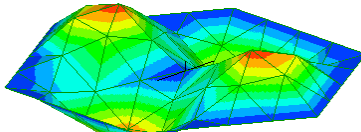
| Mode | Mode shape | Frequency |
|-----------------------------------------------------------------------------------------------------|-------------------------------------------------------------------------------------|-----------|
| 1, 0 nodal diameters |  | 2.033 Hz |
| 3, 1 nodal diameter. Mode 2 is a similar mode with the same frequency but a different orientation. |  | 3.304 Hz |
| 4, 2 nodal diameters. Mode 5 is a similar mode with the same frequency but a different orientation. |  | 4.539 Hz |

11.22 VibratingMembraneCyclicSymmetry.liml

Analysis type: Modal Vibration 3D Solid and Truss

Elements: Solid continuum (wedge6)

Loads and constraints: Fixed Support, Thermal Stress, Temperature, Cyclic Symmetry, Stress Stiffening

This is the same structure as the sample VibratingMembrane.liml but it is modeled using solid elements with stress stiffening and cyclic symmetry.

A hexagonal sheet of fabric is fixed around its outer edge and held in a state of uniform isotropic bi-axial tension. It can vibrate like a drum head due to the stiffness caused by its tension. We will find its first 3 natural frequencies and mode shapes.

The uniform stress is applied using thermal strain. An artificial thermal expansion coefficient of 1K^{-1} is used with an arbitrary small Young's modulus of 0.001N/m^2 and a temperature change of $-2 \times 10^6\text{K}$. This generates a stress of 2000N/m^2 in the plane of the membrane. You can confirm this stress by changing the analysis type to Static 3D and solving.

Because the hexagonal shape has 6 identical segments, only one segment is modeled and cyclic symmetry is used to represent the others. LISA will find modes which are cyclically symmetric as well as those that aren't. The table below shows close agreement with the results from the sample VibratingMembrane.liml.

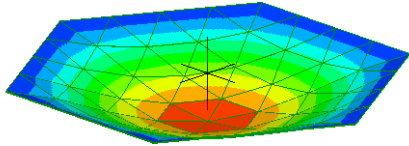
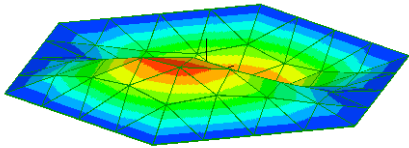
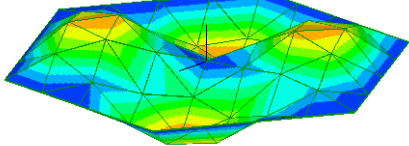
| Mode | Mode shape | Frequency |
|-----------------------------------------------------------------------------------------------------------|--------------------------------------------------------------------------------------|-----------|
| 1, 0 nodal diameters. Mode 2 is a spurious mode caused by the artificially low stiffness of the material. |  | 2.033 Hz |
| 4, 1 nodal diameter. Mode 3 is a spurious mode caused by the artificially low stiffness of the material. |  | 3.304 Hz |
| 6, 2 nodal diameters. Mode 5 is a spurious mode caused by the artificially low stiffness of the material. |  | 4.539 Hz |

11.23 VibratingString.liml

Analysis type: Modal Vibration 3D

Elements: Solid continuum (hex8)

Loads and constraints: Displacement, Stress Stiffening, Force

We will model the transverse vibration of a straight flexible cable held in tension. The cable has the following properties:

- Length: $L=60\text{m}$
- Linear density: $\rho=3\text{kg/m}$
- Tensile force: $F=40\text{N}$
- Bending stiffness: Negligible

The solution is compared to hand calculation using the formula

$$f = n/2 (F/\rho)^{1/2}/L$$

where f is the frequency and n is the mode number of the standing wave. The LISA model includes axial modes which are ignored here because they are a consequence of the arbitrary material stiffness.

| Mode | f (hand calculation) | f (LISA) |
|------|----------------------|------------|
| n=1 | 0.03043 Hz | 0.03042 Hz |
| n=2 | 0.06086 Hz | 0.06088 Hz |
| n=3 | 0.09129 Hz | 0.09141 Hz |
| n=4 | 0.1217 Hz | 0.1221 Hz |

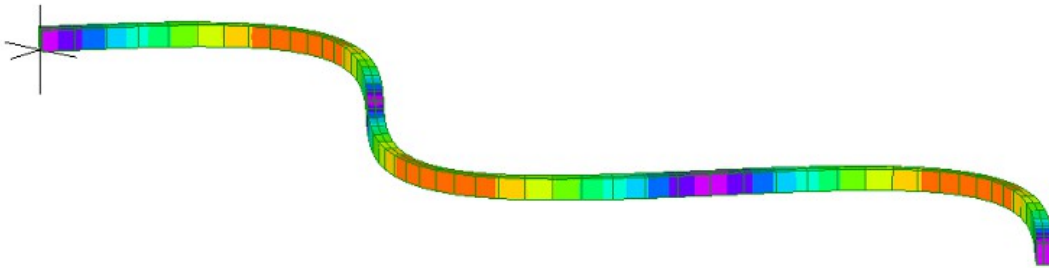

11.24 PandSWaves.liml

Analysis type: Dynamic Response 2D

Elements: Plane continuum (quad4)

Loads and constraints: Displacement, Force

Dynamic response analysis is used to model wave propagation through an elastic medium (rock). A sinusoidal force is applied at the center of an infinite domain. This generates pressure waves (P-waves) traveling outward in the direction of the force, and shear waves (S-waves) traveling outward perpendicular to the force.

Only one quadrant of the domain is modeled due to symmetry. The symmetry is enforced by constraining displacement in Y along the axes of symmetry. LISA has no infinite boundary condition so a finite boundary far from the source of the waves is used instead. The analysis is only run until the first waves reach the boundary so any reflections from the boundary are excluded.

The material's properties are:

Young's modulus $E = 7 \text{ GPa}$

Poisson's ratio $\nu = 0.2$

Density $\rho = 3000 \text{ kg/m}^3$

Shear modulus $G = \frac{E}{2(1+\nu)} = 2.917 \text{ GPa}$

Bulk modulus $K = \frac{E}{3(1-2\nu)} = 3.889 \text{ GPa}$

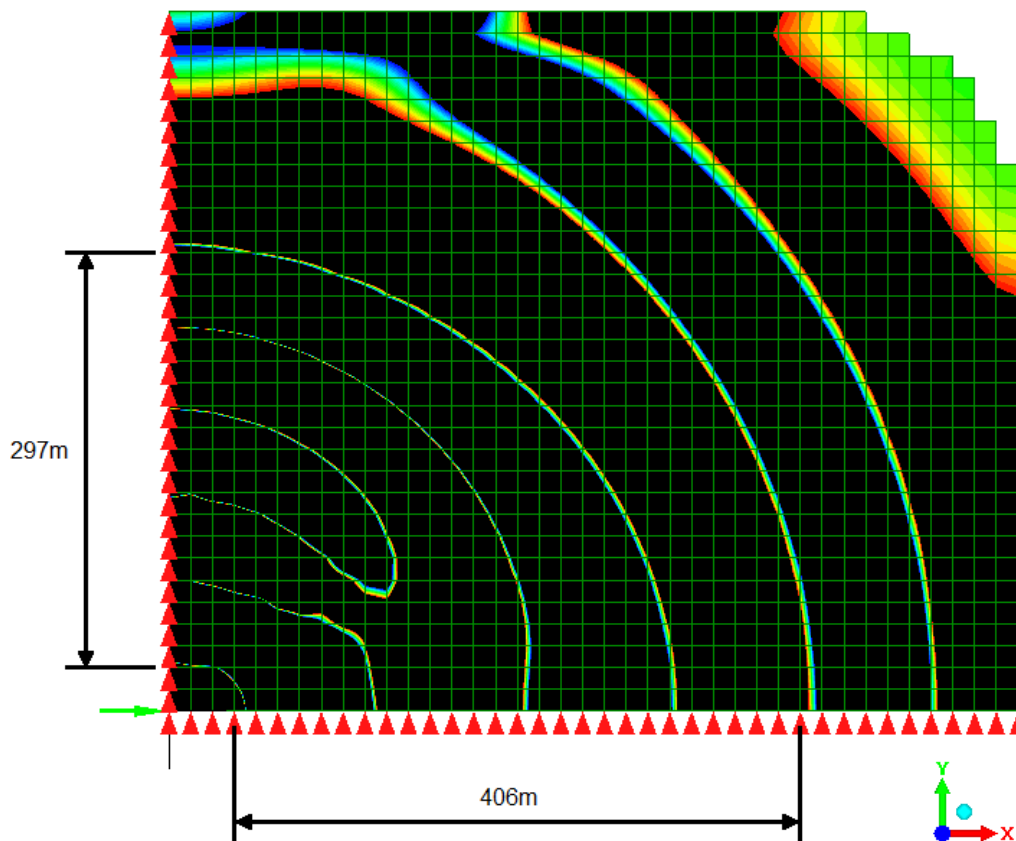

The contour plot above at time = 0.4s shows locations of zero displacement in the X direction as colored lines. This type of display is convenient for measuring wavelengths of waves of different amplitudes. It was generated by setting the **User defined maximum and minimum** to 1e12 and -1e12 respectively.

The solution is verified by comparing the wavelengths of the P-waves and S-waves to their theoretical values.

The tape measure tool is used to measure the average wavelength of two P-waves along the X axis as $406\text{m}/2 = 203\text{m}$. In the same way, the average wavelength of 2.5 S-waves measured along the Y axis is $297\text{m}/2.5 = 119\text{m}$.

The theoretical wavelengths are

$$\lambda_p = \frac{c_p}{f} \quad \text{and} \quad \lambda_s = \frac{c_s}{f}$$

where

$$f = \frac{50}{2\pi} \text{ Hz} \quad \text{is the frequency of the applied force}$$

$$c_p = \sqrt{\frac{4}{3} \frac{G+K}{\rho}} = 1610 \text{ m/s} \quad \text{is the speed of P-waves.}$$

$$c_s = \sqrt{\frac{G}{\rho}} = 986.0 \text{ m/s} \text{ is the speed of S-waves.}$$

This gives

$$\lambda_p = 202 \text{ m} \text{ and } \lambda_s = 124 \text{ m}$$

which is within 5% of LISA's results of 203m and 119m respectively.

11.25 WheatstoneBridge.liml

Analysis type: DC Current Flow

Elements: Resistor (line2), Solid continuum (hex8)

Loads and constraints: Voltage, Current

The Wheatstone bridge circuit shown below is modeled in LISA to find the voltage V_2 across R2 with an applied current of $I=100\text{mA}$. Three of the resistors are line2 resistor elements and R4 is modeled using solid elements having high-conductivity terminals to connect to the resistor elements. Node 3 is constrained to 0V and is the reference point for voltages at the other nodes.

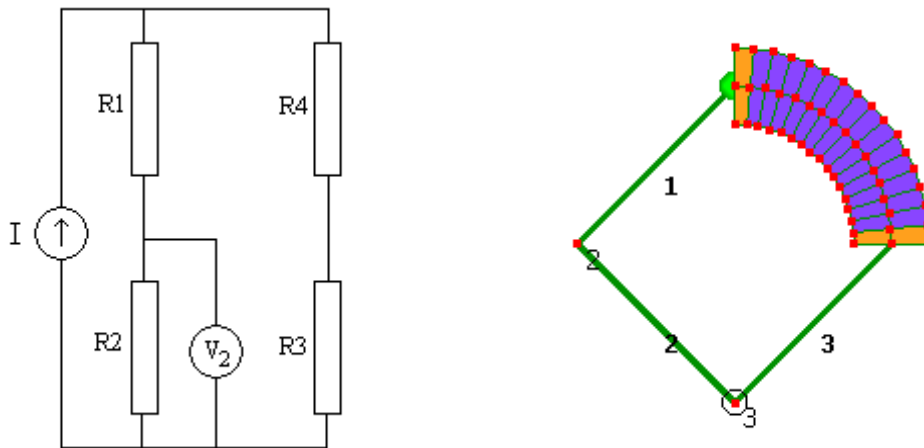

$$R1 = 750\Omega$$

$$R2 = 1000\Omega$$

$$R3 = 500\Omega$$

$$R4 = 1169.826\Omega \text{ which was found by integration of the curved shape.}$$

Hand calculation shows that the voltage at node 2 is

$$V_2 = I \frac{(R1 + R2)(R3 + R4)}{R1 + R2 + R3 + R4} \frac{R2}{R1 + R2} = 48.828\text{V}$$

which matches LISA's result of 48.823V. Most of the error is due to coarseness of the solid element mesh of R4 and can be eliminated by replacing it with a line2 resistor element having the resistance listed above.

11.26 Capacitor.liml

Analysis type: Electrostatic 3D

Elements: Solid continuum (pyr5, wedge6, hex8)

Loads and constraints: Voltage

The electric field between two plates of a capacitor will be modeled. The plates are $d=0.25\text{m}$ apart with a dielectric ($\epsilon_r=2.5$) in-between and a potential difference of $V=1.5\text{V}$ across them. Each plate has an area of $A=0.2\text{m}\times 0.3\text{m}$.

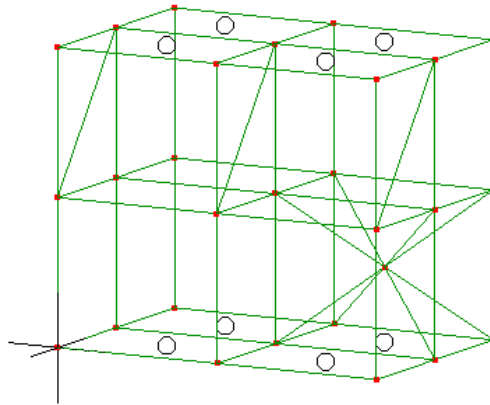

The expected electric field is

$$E = V / d \\ = 1.5\text{V} / 0.25\text{m} = 6 \text{ V/m}$$

which is consistent with the results from LISA of 6.000000 V/m on each node.

The expected energy stored in the capacitor is

$$U = 1/2 C V^2 \\ = 5.9766 \times 10^{-12} \text{ J}$$

where

$$C = A \epsilon_r \epsilon_0 / d$$

$\epsilon_0 = 8.854187818 \times 10^{-12} \text{ F/m}$, the permittivity of free space

This corresponds to an energy density of $U \times A \times d = 3.9844 \times 10^{-10} \text{ J/m}^3$. The energy density given by LISA is also $3.9844 \times 10^{-10} \text{ J/m}^3$.

Edge effects do not appear in this model because the mesh has no elements outside the area between the plates.

11.27 MagnetWire.liml

Analysis type: Magnetostatic 2D

Elements: Plane continuum (quad4)

Loads and constraints: Current, Magnetic vector potential

This model is a single infinitely long wire perpendicular to the x-y plane, with a current of $I=30\text{A}$ flowing in the +Z direction and surrounded by empty space with a relative permeability of $\mu_r=1$.

The magnitude of the magnetic field at a distance r from the center of an isolated wire is given by

$$|B| = \mu_0 I / (2\pi r)$$

At $r=0.05\text{m}$ this gives $|B|=0.120\text{mT}$ compared to LISA's solution of 0.125mT . LISA also shows the field being circular and directed counter-clockwise.

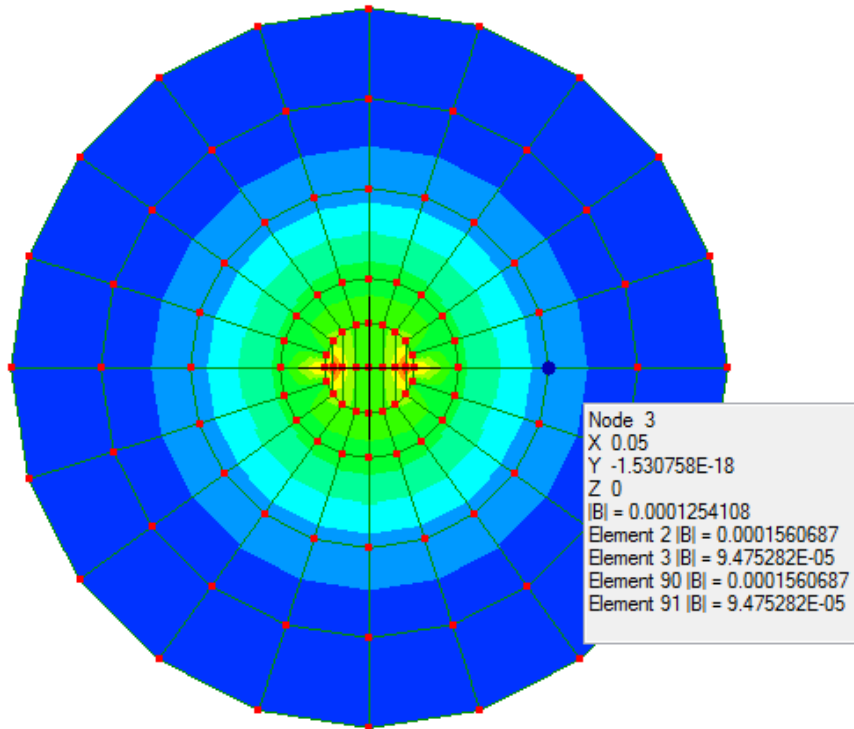

Automation and Batch Processing

12.1 Command Line Parameters

Command line parameters can be used to run LISA from another application, batch file or shell script.

```
lisa8 [<filename> [solve]]
```

The optional <filename> is a file of any of the mesh or geometry types that LISA can open. It causes LISA to start with that file open. The file name must include the extension such as .liml, .stp, etc. For example:

```
lisa8 mymodel.liml
```

If you specify a file name then the optional **solve** parameter causes LISA to solve the file then exit without displaying the main window. To obtain the solution, set an output file in the model, such as **Write solution to liml file** or a table with **Write to csv file after solving**. When you use the **solve** parameter, <filename> can contain wildcards. For example to solve all liml files in the current folder, run:

```
lisa8 *.liml solve
```

12.2 COM Interface

LISA's COM interface enables you to write programs which can call a limited range of functions inside LISA to automate some tasks. You can do this using the VBA scripting language included in Microsoft Excel.

Before you use the COM interface for the first time, you must register it. Registration creates registry keys in Windows that help other applications identify LISA and its type library. It only applies to the user running LISA so other users of the same computer will also have to register it before they use the COM interface. Select **COM registration** from the **Options** sub-menu of the **Tools** menu then click **Register** then **Close**.

A single class, lisa8.LisaCode is exposed through COM. Below is a list of all its public members:

12.2.1 General

| | | | |
|----------|---------------------------------|---------------------------------------------------------------------------|-------|
| Property | NumberOfModes() | Gets or sets the number of modes for modal vibration. | Int32 |
| Sub | Open (String FileName) | Opens the specified file. | |
| Sub | Import (String FileName) | Opens the specified file and combines it with the currently loaded model. | |

| | | | |
|----------|---------------------------------|--------------------------------------|--------|
| Sub | SaveAs (String FileName) | Saves to the specified file. | |
| Sub | PostProc () | Shows the post processor window. | |
| Sub | PreProc () | Shows the modeler window. | |
| Sub | Solve () | Solves the currently loaded model. | |
| Function | Version () | Returns the version number of LISA . | String |

12.2.2 Meshing

| | | | |
|-------------|----------------------------------------------------|-----------------------------------------------------------------------------------------------------------------------|--------|
| Function | AddNode (Double X, Double Y, Double Z) | Creates a new node at the specified coordinates. Returns its node number. | Int32 |
| Function | AddElement (Shape Shape, N1, N2, ... N20) | Creates a new element with the specified nodes. Returns its element number. | Int32 |
| Function | AddElement8 (Shape Shape, N1, N2, ... N8) | Creates a new element with the specified nodes. Returns its element number. | Int32 |
| Property | ElementNode (Int32 ElemID, Int32 LocalNode) | Gets or sets the global node number of the specified local node in an element. | Int32 |
| Function | ElementNumberOfNodes (Int32 ElemID) | Gets the number of nodes in the specified element | Int32 |
| Function | NumberOfElements () | Gets the number of elements in the model. | Int32 |
| Function | NumberOfNodes () | Gets the number of nodes in the model. | Int32 |
| Property | X (Int32 NodeID) | Gets or sets a node's X coordinate. | Double |
| Property | Y (Int32 NodeID) | Gets or sets a node's Y coordinate. | Double |
| Property | Z (Int32 NodeID) | Gets or sets a node's Z coordinate. | Double |
| Enumeration | Shape | Element shapes. To use this, the type library (LISA 8 FEA Type Library) must be added to the client's reference list. | Int32 |

12.2.3 Post-processing

| | | | |
|-------------|----------------------------------------------------------------------|-------------------------------------------------------------------------------------------------------------------------------------------------------------|--------|
| Function | AngularFrequency (Int32 Mode) | Gets the frequency of a vibration mode from the solution. | Double |
| Enumeration | FieldValue | Identifies solution field values with friendly names. To use this, the type library (LISA 8 FEA Type Library) must be added to the client's reference list. | Int32 |
| Function | NodeValue (Int32 NodeID, FieldValue FieldValue, Int32 StepNo) | Gets the solution value at a node. StepNo is either load case, time step or mode number depending on what is present in the solution. | Double |

FEA Math

13.1 Variational Principle

Physical laws of science are usually expressed as differential equations of rates of change. As the finite element method uses the computational ability of a microprocessor, the differential equation form is not immediately suitable for the finite element method. Thus, the problem has to be reformulated as a Variational Principle. The Variational Principle works with energy instead. For example, in Statics, the variational form of the problem uses the principle of minimum energy which states that : at equilibrium, the extension is such that the potential energy is a minimum.

The potential energy of an element in statics may consist of i. strain energy and ii. gravitational energy. The total energy $V(u(x))$, in the structure is given by an expression integrating the strain and gravitational energies over the entire structure. Where $u(x)$ is the nodal displacement which is a function of distance, x (here, one-dimensional analysis) and the potential energy V is a function of the nodal displacement, u .

Thus the finite element analysis problem is to find the nodal displacement $u(x)$ which minimizes the energy $V(u(x))$, yet satisfies the boundary constraints for $u(x)$ [example $u(0) = 0$ and $u(l) = b$]. $V(u(x))$ is called a functional and $u(x)$ a function. The relation between the function and functional may best be expressed by:

"given a distance, x , the nodal displacement function " u " determines a corresponding number $u(x)$ "

"given a function, u , the functional V determines a corresponding number $V(u(x))$ ".

13.2 Explaining the Functional $V(u(x))$

Consider geometrically the various functions of $u(x)$ that satisfy the boundary conditions, at $x=0$, $u=0$ and at $x=1$, $u=1$ as shown above (here only three of the infinite number of $u(x)$ functions that satisfy the boundary conditions have been shown). Any of these $u(x)$ functions when substituted into the functional $V(u(x))$ give the potential energy of the structure.

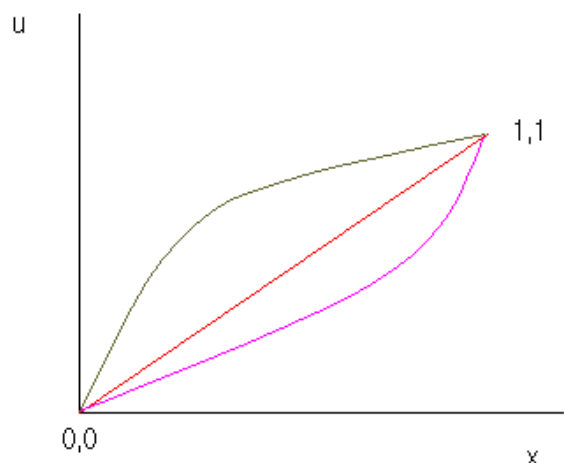

13.3 Shape Functions

An assumption has to be made about how the extension $u(x)$ varies over each element. The simplest assumption is that it varies linearly, however it can vary parabolically or according to other higher order polynomials. Instead of specifying $u(x)$ as an equation in x , an elegant and useful form of specifying $u(x)$ is in the form of a Shape Function. For example in a one dimensional element with two nodes, i and j , the shape functions

$N_i(x)$ and $N_j(x)$ may be specified as :

$N_i(x) = 1$ at $x = x_i$ and $= 0$ at $x=x_j$

$N_j(x) = 0$ at $x = x_i$ and $= 1$ at $x = x_j$

Graphically the linear one dimensional shape functions look like this.

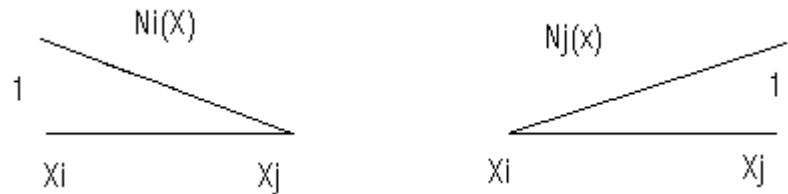

Therefore $u(x) = N_i(x)U_i + N_j(x)U_j$

Where U_i and U_j are the one-dimensional nodal displacements of the element nodes i and j . Thus, this expression for $u(x)$ is substituted in the energy equation of $V(u(x))$.

13.4 Minimizing the Functional $V(u(x))$

The finite element method finds the optimum nodal displacements U_i and U_j (one dimensional element with nodes i and j) by differentiating the functional $V(u(x))$ with respect to the nodal degrees of freedom U_i and U_j to find stationary points. A system of simultaneous equations is obtained with the nodal displacements of each element as the unknowns. These equations are represented as a stiffness matrix, load vector and unknown displacement vector.

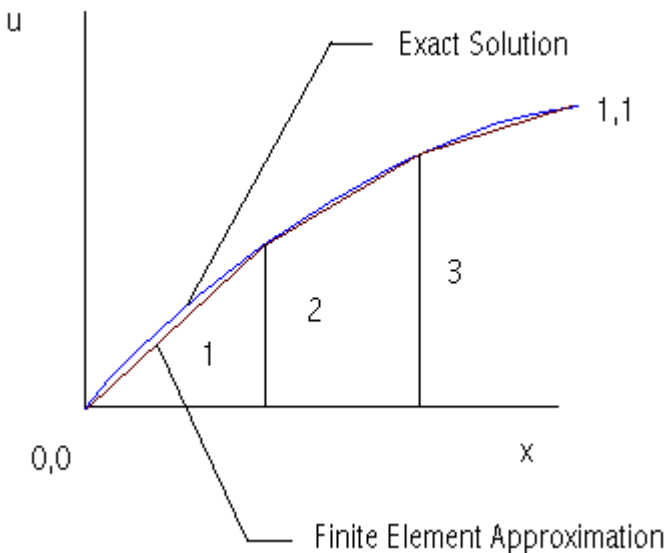

As shown, the one dimensional model has been discretized using 3 elements. The FE method finds the optimum nodal displacements such that the element nodes i, j of the all three elements approach the actual true $u(x)$ exact solution.

License Agreements

14.1 LISA

LISA may only be used in accordance with the following license agreement.

1. This agreement is between you and Sonnenhof Holdings (Canada) and relates to the LISA finite element analysis package including third party software libraries and any internet and support services provided for it, collectively referred to as "the software".
2. THE SOFTWARE IS PROVIDED "AS IS" AND WITHOUT ANY EXPRESS OR IMPLIED WARRANTIES FOR MERCHANTABILITY OR FITNESS FOR A PARTICULAR PURPOSE.
3. You must indemnify and defend Sonnenhof Holdings, its directors, staff, contractors and suppliers and the developers of and contributors to any portion of the software from any claims related to your use of the software.
4. You may not modify, redistribute, reverse engineer, decompile or disassemble the software except as provided in sections 6 and 7.
5. Parts of the software are used under license from their respective copyright holders.
6. Your use of the CAD kernel OCC is covered by the Open CASCADE Technology Public License version 6.3.
7. The Netgen nglib, Pthreads-win32 and ZedGraph libraries used by the software are covered by the GNU Lesser General Public License Version 2.1.

14.2 ARPACK

The ARPACK software library included with LISA is used under the following license.

Copyright (c) 1996-2008 Rice University.

Developed by D.C. Sorensen, R.B. Lehoucq, C. Yang, and K. Maschhoff.

All rights reserved.

Redistribution and use in source and binary forms, with or without modification, are permitted provided that the following conditions are met:

- Redistributions of source code must retain the above copyright notice, this list of conditions and the following disclaimer.
- Redistributions in binary form must reproduce the above copyright notice, this list of conditions and the following disclaimer listed in this license in the documentation and/or other materials provided with the distribution.
- Neither the name of the copyright holders nor the names of its contributors may be used to endorse or promote products derived from this software without specific prior written permission.

THIS SOFTWARE IS PROVIDED BY THE COPYRIGHT HOLDERS AND CONTRIBUTORS "AS IS" AND ANY EXPRESS OR IMPLIED WARRANTIES, INCLUDING, BUT NOT LIMITED TO, THE IMPLIED WARRANTIES OF MERCHANTABILITY AND FITNESS FOR A PARTICULAR PURPOSE ARE DISCLAIMED. IN NO EVENT SHALL THE COPYRIGHT OWNER OR CONTRIBUTORS BE LIABLE FOR ANY DIRECT, INDIRECT, INCIDENTAL, SPECIAL, EXEMPLARY, OR CONSEQUENTIAL DAMAGES (INCLUDING, BUT NOT LIMITED TO, PROCUREMENT OF SUBSTITUTE GOODS OR SERVICES; LOSS OF USE, DATA, OR PROFITS; OR BUSINESS INTERRUPTION) HOWEVER CAUSED AND ON ANY THEORY OF LIABILITY, WHETHER IN CONTRACT, STRICT LIABILITY, OR TORT (INCLUDING NEGLIGENCE OR OTHERWISE) ARISING IN ANY WAY OUT OF THE USE OF THIS SOFTWARE, EVEN IF ADVISED OF THE POSSIBILITY OF SUCH DAMAGE.

14.3 Netgen nglib, Pthreads-win32 and ZedGraph

The Netgen nglib software library included with LISA is copyright by Joachim Schoeberl. Its use is covered by the GNU Lesser General Public License Version 2.1.

The Pthreads-win32 software library release 2.8.0 included with LISA is subject to the following copyright:

Pthreads-win32 - POSIX Threads Library for Win32

Copyright(C) 1998 John E. Bossom

Copyright(C) 1999,2006 Pthreads-win32 contributors

Copying, distribution and modifications of it must be done in accordance with the GNU Lesser General Public License version 2.1.

The ZedGraph software library included with LISA is copyright by John Champion. Its use is covered by the GNU Lesser General Public License Version 2.1.

Nglib has been modified for use with LISA. If you wish to modify and/or recompile it, follow the instructions contained in lgplsource.zip which is installed in LISA's program folder.

The original source code is available from:

<http://sourceforge.net/projects/netgen-mesher/files/>

If you wish to modify and/or recompile the Pthreads-win32 library, the source code can be obtained from:

<http://sourceware.org/pthreads-win32/> or [source.zip](#) which is installed in LISA's program folder.

If you wish to modify and/or recompile the ZedGraph library, you can use the source code in [lgplsource.zip](#) which is installed in LISA's program folder or download it from:

<http://sourceforge.net/projects/zedgraph>

14.4 GNU Lesser General Public License

GNU LESSER GENERAL PUBLIC LICENSE

Version 2.1, February 1999

Copyright (C) 1991, 1999 Free Software Foundation, Inc.

51 Franklin Street, Fifth Floor, Boston, MA 02110-1301 USA

Everyone is permitted to copy and distribute verbatim copies of this license document, but changing it is not allowed.

[This is the first released version of the Lesser GPL. It also counts

as the successor of the GNU Library Public License, version 2, hence

the version number 2.1.]

Preamble

The licenses for most software are designed to take away your freedom to share and change it. By contrast, the GNU General Public Licenses are intended to guarantee your freedom to share and change free software--to make sure the software is free for all its users.

This license, the Lesser General Public License, applies to some specially designated software packages--typically libraries--of the Free Software Foundation and other authors who decide to use it. You can use it too, but we suggest you first think carefully about whether this license or the ordinary General Public License is the better strategy to use in any particular case, based on the explanations below.

When we speak of free software, we are referring to freedom of use, not price. Our General Public Licenses are designed to make sure that you have the freedom to distribute copies of free software (and charge for this service if you wish); that you receive source code or can get it if you want it; that you can change the software and use pieces of it in new free programs; and that you are informed that you can do these things.

To protect your rights, we need to make restrictions that forbid distributors to deny you these rights or to ask you to surrender these rights. These restrictions translate to certain responsibilities for you if you distribute copies of the library or if you modify it.

For example, if you distribute copies of the library, whether gratis or for a fee, you must give the recipients all the rights that we gave you. You must make sure that they, too, receive or can get the source code. If you link other code with the library, you must provide complete object files to the recipients, so that they can relink them with the library after making changes to the library and recompiling it. And you must show them these terms so they know their rights.

We protect your rights with a two-step method: (1) we copyright the library, and (2) we offer you this license, which gives you legal permission to copy, distribute and/or modify the library.

To protect each distributor, we want to make it very clear that there is no warranty for the free library. Also, if the library is modified by someone else and passed on, the recipients should know that what they have is not the original version, so that the original author's reputation will not be affected by problems that might be introduced by others.

Finally, software patents pose a constant threat to the existence of any free program. We wish to make sure that a company cannot effectively restrict the users of a free program by obtaining a restrictive license from a patent holder. Therefore, we insist that any patent license obtained for a version of the library must be consistent with the full freedom of use specified in this license.

Most GNU software, including some libraries, is covered by the ordinary GNU General Public License. This license, the GNU Lesser General Public License, applies to certain designated libraries, and is quite different from the ordinary General Public License. We use this license for certain libraries in order to permit linking those libraries into non-free programs.

When a program is linked with a library, whether statically or using a shared library, the combination of the two is legally speaking a combined work, a derivative of the original library. The ordinary General Public License therefore permits such linking only if the entire combination fits its criteria of freedom. The Lesser General Public License permits more lax criteria for linking other code with the library.

We call this license the "Lesser" General Public License because it does Less to protect the user's freedom than the ordinary General Public License. It also provides other free software developers Less of an advantage over competing non-free programs. These disadvantages are the reason we use the ordinary General Public License for many libraries. However, the Lesser license provides advantages in certain special circumstances.

For example, on rare occasions, there may be a special need to encourage the widest possible use of a certain library, so that it becomes a de-facto standard. To achieve this, non-free programs must be allowed to use the library. A more frequent case is that a free library does the same job as widely used non-free libraries. In this case, there is little to gain by limiting the free library to free software only, so we use the Lesser General Public License.

In other cases, permission to use a particular library in non-free programs enables a greater number of people to use a large body of free software. For example, permission to use the GNU C Library in non-free programs enables many more people to use the whole GNU operating system, as well as its variant, the GNU/Linux operating system.

Although the Lesser General Public License is Less protective of the users' freedom, it does ensure that the user of a program that is linked with the Library has the freedom and the wherewithal to run that program using a modified version of the Library.

The precise terms and conditions for copying, distribution and modification follow. Pay close attention to the difference between a "work based on the library" and a "work that uses the library". The former contains code derived from the library, whereas the latter must be combined with the library in order to run.

TERMS AND CONDITIONS FOR COPYING, DISTRIBUTION AND MODIFICATION

0. This License Agreement applies to any software library or other program which contains a notice placed by the copyright holder or other authorized party saying it may be distributed under the terms of this Lesser General Public License (also called "this License"). Each licensee is addressed as "you".

A "library" means a collection of software functions and/or data prepared so as to be conveniently linked with application programs (which use some of those functions and data) to form executables.

The "Library", below, refers to any such software library or work which has been distributed under these terms. A "work based on the Library" means either the Library or any derivative work under copyright law: that is to say, a work containing the Library or a portion of it, either verbatim or with modifications and/or translated straightforwardly into another language. (Hereinafter, translation is included without limitation in the term "modification".)

"Source code" for a work means the preferred form of the work for making modifications to it. For a library, complete source code means all the source code for all modules it contains, plus any associated interface definition files, plus the scripts used to control compilation and installation of the library.

Activities other than copying, distribution and modification are not covered by this License; they are outside its scope. The act of running a program using the Library is not restricted, and output from such a program is covered only if its contents constitute a work based on the Library (independent of the use of the Library in a tool for writing it). Whether that is true depends on what the Library does and what the program that uses the Library does.

1. You may copy and distribute verbatim copies of the Library's complete source code as you receive it, in any medium, provided that you conspicuously and appropriately publish on each copy an appropriate copyright notice and disclaimer of warranty; keep intact all the notices that refer to this License and to the absence of any warranty; and distribute a copy of this License along with the Library.

You may charge a fee for the physical act of transferring a copy, and you may at your option offer warranty protection in exchange for a fee.

2. You may modify your copy or copies of the Library or any portion of it, thus forming a work based on the Library, and copy and distribute such modifications or work under the terms of Section 1 above, provided that you also meet all of these conditions:

- The modified work must itself be a software library.
- You must cause the files modified to carry prominent notices stating that you changed the files and the date of any change.
- You must cause the whole of the work to be licensed at no charge to all third parties under the terms of this License.
- If a facility in the modified Library refers to a function or a table of data to be supplied by an application program that uses the facility, other than as an argument passed when the facility is invoked, then you must make a good faith effort to ensure that, in the event an application does not supply such function or table, the facility still operates, and performs whatever part of its purpose remains meaningful.

(For example, a function in a library to compute square roots has a purpose that is entirely well-defined independent of the application. Therefore, Subsection 2d requires that any application-supplied function or table used by this function must be optional: if the application does not supply it, the square root function must still compute square roots.)

These requirements apply to the modified work as a whole. If identifiable sections of that work are not derived from the Library, and can be reasonably considered independent and separate works in themselves, then this License, and its terms, do not apply to those sections when you distribute them as separate works. But when you distribute the same sections as part of a whole which is a work based on the Library, the distribution of the whole must be on the terms of this License, whose permissions for other licensees extend to the entire whole, and thus to each and every part regardless of who wrote it.

Thus, it is not the intent of this section to claim rights or contest your rights to work written entirely by you; rather, the intent is to exercise the right to control the distribution of derivative or collective works based on the Library.

In addition, mere aggregation of another work not based on the Library with the Library (or with a work based on the Library) on a volume of a storage or distribution medium does not bring the other work under the scope of this License.

3. You may opt to apply the terms of the ordinary GNU General Public License instead of this License to a given copy of the Library. To do this, you must alter all the notices that refer to this License, so that they refer to the ordinary GNU General Public License, version 2, instead of to this License. (If a newer version than version 2 of the ordinary GNU General Public License has appeared, then you can specify that version instead if you wish.) Do not make any other change in these notices.

Once this change is made in a given copy, it is irreversible for that copy, so the ordinary GNU General Public License applies to all subsequent copies and derivative works made from that copy.

This option is useful when you wish to copy part of the code of the Library into a program that is not a library.

4. You may copy and distribute the Library (or a portion or derivative of it, under Section 2) in object code or executable form under the terms of Sections 1 and 2 above provided that you accompany it with the complete corresponding machine-readable source code, which must be distributed under the terms of Sections 1 and 2 above on a medium customarily used for software interchange.

If distribution of object code is made by offering access to copy from a designated place, then offering equivalent access to copy the source code from the same place satisfies the requirement to distribute the source code, even though third parties are not compelled to copy the source along with the object code.

5. A program that contains no derivative of any portion of the Library, but is designed to work with the Library by being compiled or linked with it, is called a "work that uses the Library". Such a work, in isolation, is not a derivative work of the Library, and therefore falls outside the scope of this License.

However, linking a "work that uses the Library" with the Library creates an executable that is a derivative of the Library (because it contains portions of the Library), rather than a "work that uses the library". The executable is therefore covered by this License. Section 6 states terms for distribution of such executables.

When a "work that uses the Library" uses material from a header file that is part of the Library, the object code for the work may be a derivative work of the Library even though the source code is not. Whether this is true is especially significant if the work can be linked without the Library, or if the work is itself a library. The threshold for this to be true is not precisely defined by law.

If such an object file uses only numerical parameters, data structure layouts and accessors, and small macros and small inline functions (ten lines or less in length), then the use of the object file is unrestricted, regardless of whether it is legally a derivative work. (Executables containing this object code plus portions of the Library will still fall under Section 6.)

Otherwise, if the work is a derivative of the Library, you may distribute the object code for the work under the terms of Section 6. Any executables containing that work also fall under Section 6, whether or not they are linked directly with the Library itself.

6. As an exception to the Sections above, you may also combine or link a "work that uses the Library" with the Library to produce a work containing portions of the Library, and distribute that work under terms of your choice, provided that the terms permit modification of the work for the customer's own use and reverse engineering for debugging such modifications.

You must give prominent notice with each copy of the work that the Library is used in it and that the Library and its use are covered by this License. You must supply a copy of this License. If the work during execution displays copyright notices, you must include the copyright notice for the Library among them, as well as a reference directing the user to the copy of this License. Also, you must do one of these things:

a) Accompany the work with the complete corresponding machine-readable source code for the Library including whatever changes were used in the work (which must be distributed under Sections 1 and 2 above); and, if the work is an executable linked with the Library, with the complete machine-readable "work that uses the Library", as object code and/or source code, so that the user can modify the Library and then relink to produce a modified executable containing the modified Library. (It is understood that the user who changes the contents of definitions files in the Library will not necessarily be able to recompile the application to use the modified definitions.)

b) Use a suitable shared library mechanism for linking with the Library. A suitable mechanism is one that (1) uses at run time a copy of the library already present on the user's computer system, rather than copying library functions into the executable, and (2) will operate properly with a modified version of the library, if the user installs one, as long as the modified version is interface-compatible with the version that the work was made with.

c) Accompany the work with a written offer, valid for at least three years, to give the same user the materials specified in Subsection 6a, above, for a charge no more than the cost of performing this distribution.

d) If distribution of the work is made by offering access to copy from a designated place, offer equivalent access to copy the above specified materials from the same place.

e) Verify that the user has already received a copy of these materials or that you have already sent this user a copy.

For an executable, the required form of the "work that uses the Library" must include any data and utility programs needed for reproducing the executable from it. However, as a special exception, the materials to be distributed need not include anything that is normally distributed (in either source or binary form) with the major components (compiler, kernel, and so on) of the operating system on which the executable runs, unless that component itself accompanies the executable.

It may happen that this requirement contradicts the license restrictions of other proprietary libraries that do not normally accompany the operating system. Such a contradiction means you cannot use both them and the Library together in an executable that you distribute.

7. You may place library facilities that are a work based on the Library side-by-side in a single library together with other library facilities not covered by this License, and distribute such a combined library, provided that the separate distribution of the work based on the Library and of the other library facilities is otherwise permitted, and provided that you do these two things:

a) Accompany the combined library with a copy of the same work based on the Library, uncombined with any other library facilities. This must be distributed under the terms of the Sections above.

b) Give prominent notice with the combined library of the fact that part of it is a work based on the Library, and explaining where to find the accompanying uncombined form of the same work.

8. You may not copy, modify, sublicense, link with, or distribute the Library except as expressly provided under this License. Any attempt otherwise to copy, modify, sublicense, link with, or distribute the Library is void, and will automatically terminate your rights under this License. However, parties who have received copies, or rights, from you under this License will not have their licenses terminated so long as such parties remain in full compliance.

9. You are not required to accept this License, since you have not signed it. However, nothing else grants you permission to modify or distribute the Library or its derivative works. These actions are prohibited by law if you do not accept this License. Therefore, by

modifying or distributing the Library (or any work based on the Library), you indicate your acceptance of this License to do so, and all its terms and conditions for copying, distributing or modifying the Library or works based on it.

10. Each time you redistribute the Library (or any work based on the Library), the recipient automatically receives a license from the original licensor to copy, distribute, link with or modify the Library subject to these terms and conditions. You may not impose any further restrictions on the recipients' exercise of the rights granted herein. You are not responsible for enforcing compliance by third parties with this License.

11. If, as a consequence of a court judgment or allegation of patent infringement or for any other reason (not limited to patent issues), conditions are imposed on you (whether by court order, agreement or otherwise) that contradict the conditions of this License, they do not excuse you from the conditions of this License. If you cannot distribute so as to satisfy simultaneously your obligations under this License and any other pertinent obligations, then as a consequence you may not distribute the Library at all. For example, if a patent license would not permit royalty-free redistribution of the Library by all those who receive copies directly or indirectly through you, then the only way you could satisfy both it and this License would be to refrain entirely from distribution of the Library.

If any portion of this section is held invalid or unenforceable under any particular circumstance, the balance of the section is intended to apply, and the section as a whole is intended to apply in other circumstances.

It is not the purpose of this section to induce you to infringe any patents or other property right claims or to contest validity of any such claims; this section has the sole purpose of protecting the integrity of the free software distribution system which is implemented by public license practices. Many people have made generous contributions to the wide range of software distributed through that system in reliance on consistent application of that system; it is up to the author/donor to decide if he or she is willing to distribute software through any other system and a licensee cannot impose that choice.

This section is intended to make thoroughly clear what is believed to be a consequence of the rest of this License.

12. If the distribution and/or use of the Library is restricted in certain countries either by patents or by copyrighted interfaces, the original copyright holder who places the Library under this License may add an explicit geographical distribution limitation excluding those countries, so that distribution is permitted only in or among countries not thus excluded. In such case, this License incorporates the limitation as if written in the body of this License.

13. The Free Software Foundation may publish revised and/or new versions of the Lesser General Public License from time to time. Such new versions will be similar in spirit to the present version, but may differ in detail to address new problems or concerns.

Each version is given a distinguishing version number. If the Library specifies a version number of this License which applies to it and "any later version", you have the option of following the terms and conditions either of that version or of any later version published by the Free Software Foundation. If the Library does not specify a license version number, you may choose any version ever published by the Free Software Foundation.

14. If you wish to incorporate parts of the Library into other free programs whose distribution conditions are incompatible with these, write to the author to ask for permission. For software which is copyrighted by the Free Software Foundation, write to the Free Software Foundation; we sometimes make exceptions for this. Our decision will be guided by the two goals of preserving the free status of all derivatives of our free software and of promoting the sharing and reuse of software generally.

NO WARRANTY

15. BECAUSE THE LIBRARY IS LICENSED FREE OF CHARGE, THERE IS NO WARRANTY FOR THE LIBRARY, TO THE EXTENT PERMITTED BY APPLICABLE LAW. EXCEPT WHEN OTHERWISE STATED IN WRITING THE COPYRIGHT HOLDERS AND/OR OTHER PARTIES PROVIDE THE LIBRARY "AS IS" WITHOUT WARRANTY OF ANY KIND, EITHER EXPRESSED OR IMPLIED, INCLUDING, BUT NOT LIMITED TO, THE IMPLIED WARRANTIES OF MERCHANTABILITY AND FITNESS FOR A PARTICULAR PURPOSE. THE ENTIRE RISK AS TO THE QUALITY AND PERFORMANCE OF THE LIBRARY IS WITH YOU. SHOULD THE LIBRARY PROVE DEFECTIVE, YOU ASSUME THE COST OF ALL NECESSARY SERVICING, REPAIR OR CORRECTION.

16. IN NO EVENT UNLESS REQUIRED BY APPLICABLE LAW OR AGREED TO IN WRITING WILL ANY COPYRIGHT HOLDER, OR ANY OTHER PARTY WHO MAY MODIFY AND/OR REDISTRIBUTE THE LIBRARY AS PERMITTED ABOVE, BE LIABLE TO YOU FOR DAMAGES, INCLUDING ANY GENERAL, SPECIAL, INCIDENTAL OR CONSEQUENTIAL DAMAGES ARISING OUT OF THE USE OR INABILITY TO USE THE LIBRARY (INCLUDING BUT NOT LIMITED TO LOSS OF DATA OR DATA BEING RENDERED INACCURATE OR LOSSES SUSTAINED BY YOU OR THIRD PARTIES OR A FAILURE OF THE LIBRARY TO OPERATE WITH ANY OTHER SOFTWARE), EVEN IF SUCH HOLDER OR OTHER PARTY HAS BEEN ADVISED OF THE POSSIBILITY OF SUCH DAMAGES.

END OF TERMS AND CONDITIONS

How to Apply These Terms to Your New Libraries

If you develop a new library, and you want it to be of the greatest possible use to the public, we recommend making it free software that everyone can redistribute and change. You can do so by permitting redistribution under these terms (or, alternatively, under the terms of the ordinary General Public License).

To apply these terms, attach the following notices to the library. It is safest to attach them to the start of each source file to most effectively convey the exclusion of warranty; and each file should have at least the "copyright" line and a pointer to where the full notice is found.

one line to give the library's name and an idea of what it does.

Copyright (C) year name of author

This library is free software; you can redistribute it and/or modify it under the terms of the GNU Lesser General Public License as published by the Free Software Foundation; either version 2.1 of the License, or (at your option) any later version.

This library is distributed in the hope that it will be useful, but WITHOUT ANY WARRANTY; without even the implied warranty of MERCHANTABILITY or FITNESS FOR A PARTICULAR PURPOSE. See the GNU Lesser General Public License for more details.

You should have received a copy of the GNU Lesser General Public License along with this library; if not, write to the Free Software Foundation, Inc., 51 Franklin Street, Fifth Floor, Boston, MA 02110-1301 USA

Also add information on how to contact you by electronic and paper mail.

You should also get your employer (if you work as a programmer) or your school, if any, to sign a "copyright disclaimer" for the library, if necessary. Here is a sample; alter the names:

Yoyodyne, Inc., hereby disclaims all copyright interest in the library `Frob' (a library for tweaking knobs) written by James Random Hacker.

signature of Ty Coon, 1 April 1990

Ty Coon, President of Vice

That's all there is to it!

14.5 OCC CAD Kernel

Parts of version 6.3 of OCC are included with LISA. The source code is available from <http://www.opencascade.org/>. It is used under the following license agreement.

Open CASCADE Technology Public License

License version : 6.3 August, 2008

Open CASCADE S.A.S. releases and makes publicly available the source code of the software Open CASCADE Technology to the free software development community under the terms and conditions of this license.

It is not the purpose of this license to induce you to infringe any patents or other property right claims or to contest validity of any such claims; this license has the sole purpose of protecting the integrity of the free software distribution system, which is implemented by public license practices. Many people have made generous contributions to the wide range of software distributed through that system in reliance on consistent application of that system; it is up to the author/donor to decide if he or she is willing to distribute software through any other system and a licensee cannot impose that choice.

Please read this license carefully and completely before downloading this software. By downloading, using, modifying, distributing and sublicensing this software, you indicate your acceptance to be bound by the terms and conditions of this license. If you do not want to accept or cannot accept for any reasons the terms and conditions of this license, please do not download or use in any manner this software.

1. Definitions

Unless there is something in the subject matter or in the context inconsistent therewith, the capitalized terms used in this License shall have the following meaning.

"Applicable Intellectual Property Rights" means (a) with respect to the Initial Developer, any rights under patents or patents applications or other intellectual property rights that are now

or hereafter acquired, owned by or assigned to the Initial Developer and that cover subject matter contained in the Original Code, but only to the extent necessary to use, reproduce, modify, distribute or sublicense the Original Code without infringement; and (b) with respect to You or any Contributor, any rights under patents or patents applications or other intellectual property rights that are now or hereafter acquired, owned by or assigned to You or to such Contributor and that cover subject matter contained in Your Modifications or in such Contributor's Modifications, taken alone or in combination with Original Code

"Contributor" means each individual or legal entity that creates or contributes to the creation of any Modification, including the Initial Developer.

"Derivative Program": means a new program combining the Software or portions thereof with other source code not governed by the terms of this License.

"Initial Developer": means Open CASCADE S.A.S., with main offices at Tour Opus 12, 77, Esplanade du Général de Gaulle, 92914, Paris, La Défense Cedex, France.

"Modifications": mean any addition to, deletion from or change to the substance or the structure of the Software. When source code of the Software is released as a series of files, a Modification is: (a) any addition to, deletion from or change to the contents of a file containing the Software or (b) any new file or other representation of computer program statements that contains any part of the Software. By way of example, Modifications include any debug of, or improvement to, the Original Code or any of its components or portions as well as its next versions or releases thereof.

"Original Code": means (a) the source code of the software Open CASCADE Technology originally made available by the Initial Developer under this License, including the source code of any updates or upgrades of the Original Code and (b) the object code compiled from such source code and originally made available by Initial Developer under this License.

"Software": means the Original Code, the Modifications, the combination of Original Code and any Modifications or any respective portions thereof.

"You" or "Your": means an individual or a legal entity exercising rights under this License

2. Acceptance of license

By using, reproducing, modifying, distributing or sublicensing the Software or any portion thereof, You expressly indicate Your acceptance of the terms and conditions of this License and undertake to act in accordance with all the provisions of this License applicable to You.

3. Scope and purpose

This License applies to the Software and You may not use, reproduce, modify, distribute, sublicense or circulate the Software, or any portion thereof, except as expressly provided under this License. Any attempt to otherwise use, reproduce, modify, distribute or sublicense the Software is void and will automatically terminate Your rights under this License.

4. Contributor license

Subject to the terms and conditions of this License, the Initial Developer and each of the Contributors hereby grant You a world-wide, royalty-free, irrevocable and non-exclusive license under the Applicable Intellectual Property Rights they own or control, to use, reproduce, modify, distribute and sublicense the Software provided that:

You reproduce in all copies of the Software the copyright and other proprietary notices and disclaimers of the Initial Developer as they appear in the Original Code and attached hereto as Schedule "A" and any other notices or disclaimers attached to the Software and keep intact all notices in the Original Code that refer to this License and to the absence of any warranty;

You include a copy of this License with every copy of the Software You distribute;

If you distribute or sublicense the Software (as modified by You or on Your behalf as the case may be), You cause such Software to be licensed as a whole, at no charge, to all third parties, under the terms and conditions of the License, making in particular available to all third parties the source code of the Software;

You document all Your Modifications, indicate the date of each such Modifications, designate the version of the Software You used, prominently include a file carrying such information with respect to the Modifications and duplicate the copyright and other proprietary notices and disclaimers attached hereto as Schedule "B" or any other notices or disclaimers attached to the Software with your Modifications.

For greater certainty, it is expressly understood that You may freely create Derivative Programs (without any obligation to publish such Derivative Program) and distribute same as a single product. In such case, You must ensure that all the requirements of this License are fulfilled for the Software or any portion thereof.

5. Your license

You hereby grant all Contributors and anyone who becomes a party under this License a world-wide, non-exclusive, royalty-free and irrevocable license under the Applicable Intellectual Property Rights owned or controlled by You, to use, reproduce, modify, distribute and sublicense all Your Modifications under the terms and conditions of this License.

6. Software subject to license

Your Modifications shall be governed by the terms and conditions of this License. You are not authorized to impose any other terms or conditions than those prevailing under this License when You distribute and/or sublicense the Software, save and except as permitted under Section 7 hereof.

7. Additional terms

You may choose to offer, on a non-exclusive basis, and to charge a fee for any warranty, support, maintenance, liability obligations or other rights consistent with the scope of this License with respect to the Software (the "Additional Terms") to the recipients of the Software. However, You may do so only on Your own behalf and on Your sole and exclusive responsibility. You must obtain the recipient's agreement that any such Additional Terms are offered by You alone, and You hereby agree to indemnify, defend and hold the Initial Developer and any Contributor harmless for any liability incurred by or claims asserted against the Initial Developer or any Contributors with respect to any such Additional Terms.

8. Disclaimer of warranty

The Software is provided under this License on an "as is" basis, without warranty of any kind, including without limitation, warranties that the Software is free of defects, merchantable, fit for a particular purpose or non-infringing. The entire risk as to the quality and performance of the Software is with You.

9. Liability

Under no circumstances shall You, the Initial Developer or any Contributor be liable to any person for any direct or indirect damages of any kind including, without limitation, damages for loss of goodwill, loss of data, work stoppage, computer failure or malfunction or any and all other commercial damages or losses resulting from or relating to this License or indirectly to the use of the Software.

10. Trademark

This License does not grant any rights to use the trademarks, trade names and domain names "MATRA", "EADS Matra Datavision", "CAS.CADE", "Open CASCADE", "opencascade.com" and "opencascade.org" or any other trademarks, trade names or domain names used or owned by the Initial Developer.

11. Copyright

The Initial Developer retains all rights, title and interest in and to the Original Code. You may not remove the copyright © notice which appears when You download the Software.

12. Term

This License is granted to You for a term equal to the remaining period of protection covered by the intellectual property rights applicable to the Original Code.

13. Termination

In case of termination, as provided in Section 3 above, You agree to immediately stop any further use, reproduction, modification, distribution and sublicensing of the Software and to destroy all copies of the Software that are in Your possession or control. All sublicenses of the Software which have been properly granted prior to termination shall survive any termination of this License. In addition, Sections 5, 8 to 11, 13.2 and 15.2 of this License, in reason of their nature, shall survive the termination of this License for a period of fifteen (15) years.

14. Versions of the license

The Initial Developer may publish new versions of this License from time to time. Once Original Code has been published under a particular version of this License, You may choose to continue to use it under the terms and conditions of that version or use the Original Code under the terms of any subsequent version of this License published by the Initial Developer.

15. Miscellaneous

15.1 Relationship of the Parties

This License will not be construed as creating an agency, partnership, joint venture or any other form of legal association between You and the Initial Developer, and You will not represent to the contrary, whether expressly, by implication or otherwise.

15.2 Independent Development

Nothing in this License will impair the Initial Developer's right to acquire, license, develop, have others develop for it, market or distribute technology or products that perform the same or similar functions as, or otherwise compete with, Modifications, Derivative Programs, technology or products that You may develop, produce, market or distribute.

15.3 Severability

If for any reason a court of competent jurisdiction finds any provision of this License, or portion thereof, to be unenforceable, that provision of the License will be enforced to the maximum extent permissible so as to effect the economic benefits and intent of the parties, and the remainder of this License will continue in full force and extent.

END OF THE TERMS AND CONDITIONS OF THIS LICENSE

Open CASCADE S.A.S. is a French société par actions simplifiée having its registered head office at 31, avenue de la Baltique, 91954 Les Ulis Cedex, France and main offices at Tour Opus 12, 77, Esplanade du Général de Gaulle, 92914, Paris, La Défense Cedex, France. Its web site is located at the following address www.opencascade.com

Open CASCADE Technology Public License

Schedule "A"

The content of this file is subject to the Open CASCADE Technology Public License Version 6.2 (the "License"). You may not use the content of this file except in compliance with the License. Please obtain a copy of the License at <http://www.opencascade.org> and read it completely before using this file.

The Initial Developer of the Original Code is Open CASCADE S.A.S., with main offices at Tour Opus 12, 77, Esplanade du Général de Gaulle, 92914, Paris, La Défense Cedex, France. The Original Code is copyright © Open CASCADE S.A.S., 2001. All rights reserved.

"The Original Code and all software distributed under the License are distributed on an "AS IS" basis, without warranty of any kind, and the Initial Developer hereby disclaims all such warranties, including without limitation, any warranties of merchantability, fitness for a particular purpose or non-infringement.

Please see the License for the specific terms and conditions governing rights and limitations under the License".

End of Schedule "A"

Open CASCADE Technology Public License

Schedule "B"

"The content of this file is subject to the Open CASCADE Technology Public License Version 6.2 (the "License"). You may not use the content of this file except in compliance with the License. Please obtain a copy of the License at <http://www.opencascade.org> and read it completely before using this file.

The Initial Developer of the Original Code is Open CASCADE S.A.S., with main offices at Tour Opus 12, 77, Esplanade du Général de Gaulle, 92914, Paris, La Défense Cedex, France. The Original Code is copyright © Open CASCADE S.A.S., 2001. All rights reserved.

Modifications to the Original Code have been made by _____.
Modifications are copyright © [Year to be included]. All rights reserved.

The software Open CASCADE Technology and all software distributed under the License are distributed on an "AS IS" basis, without warranty of any kind, and the Initial Developer hereby disclaims all such warranties, including without limitation, any warranties of merchantability, fitness for a particular purpose or non-infringement. Please see the License for the specific terms and conditions governing rights and limitations under the License"

End of Schedule "B"

References

- 1: C. Taylor & T. G. Hughes, Finite Element Programming of The Navier-Stokes Equations,
- 2: D. L. Thomas, Dynamics of Rotationally Periodic Structures, 1979
- 3: Warren C. Young, Roark's Formulas for Stress & Strain,
- 4: H. R. Schwarz, Methode der finiten Elemente, 1991
- 5: Walter Michaeli, Extrusionswerkzeuge fuer Kunststoffe und Kautschuk, 1991
- 6: S. S. Rao, The Finite Element Method in Engineering, 1989
- 7: William Weaver, Jr., Stephen P. Timoshenko, Donovan H. Young, Vibration Problems in Engineering, 1990